



Ferrell-Ross

A.T. Ferrell Company Inc.

Ferrell-Ross 24X56 and 32X68 Pinnacle Series

The Ferrell-Ross 24x56 & 32x68 Pinnacle Series are engineered to deliver maximum performance at high production rates. Designed for large-scale steam flaking applications, the 24x56 produces up to 28 TPH, while the 32x68 delivers up to 40 TPH, providing exceptional capacity and consistent flake quality. Both models reduce installation time and energy consumption, with high-torque, lower-horsepower motors that come pre-mounted and ready to run, allowing facilities to realize immediate energy savings and reliable operation from day one.

Built on decades of Ferrell-Ross design expertise, the Pinnacle Series features a super-duty structural steel frame built for long service life. Precision-machined steel bearing housings paired with 6" bore hydraulic cylinders generate the high linear roll pressures required for uniform flake thickness and density. Chilled cast iron rolls, a dual-drive configuration for optimal roll surface speed, and a high-capacity peg shaft feed system combine to deliver durability, efficiency, and consistent high-volume performance and uptime.

Standard Features:

- High Quality 24" or 32" Diameter X 56" or 68" Wide Chilled Cast Iron Rolls
- Mill Frame Constructed from High-Strength Structural Steel
- Stainless Steel Mill Housing Roll Covers
- Stainless Steel Mill Housing Center Section
- (2) Roll Inspection Doors
- Hydraulic Roll Tension
- Fixator Positive Roll Stops
- Hydraulic Accumulator Roll Protection
- Air-Over Hydraulic Pump with Electric and Manual 4-way Valve
- Heavy Duty Steel Bearing Housings
- Double-Row, Self-Aligning Spherical Roller Bearings
- Dual HTD Drive
- Adjustable Motor Bases
- Cabinet style Drive Guards, OSHA Type
- Stainless Steel Roll Scraper Assemblies with Aluminum Blades
- Stainless Steel Peg Feeder with Adjustable Slide Gate
- Adjustable Internal Deflector
- Convenient Central Greasing System
- Product Sampling Doors
- Roll Pre-Heat System (requires steam connection)

Precision Milling Solutions for Every Process

1440 South Adams Street, Bluffton, IN 46714 USA (260) 824-3400 (800) 248-8318 Fax (260) 824-5463

E-mail sales@atferrell.com Web www.atferrell.com

Get the factory-authorized parts you need. Call us today.

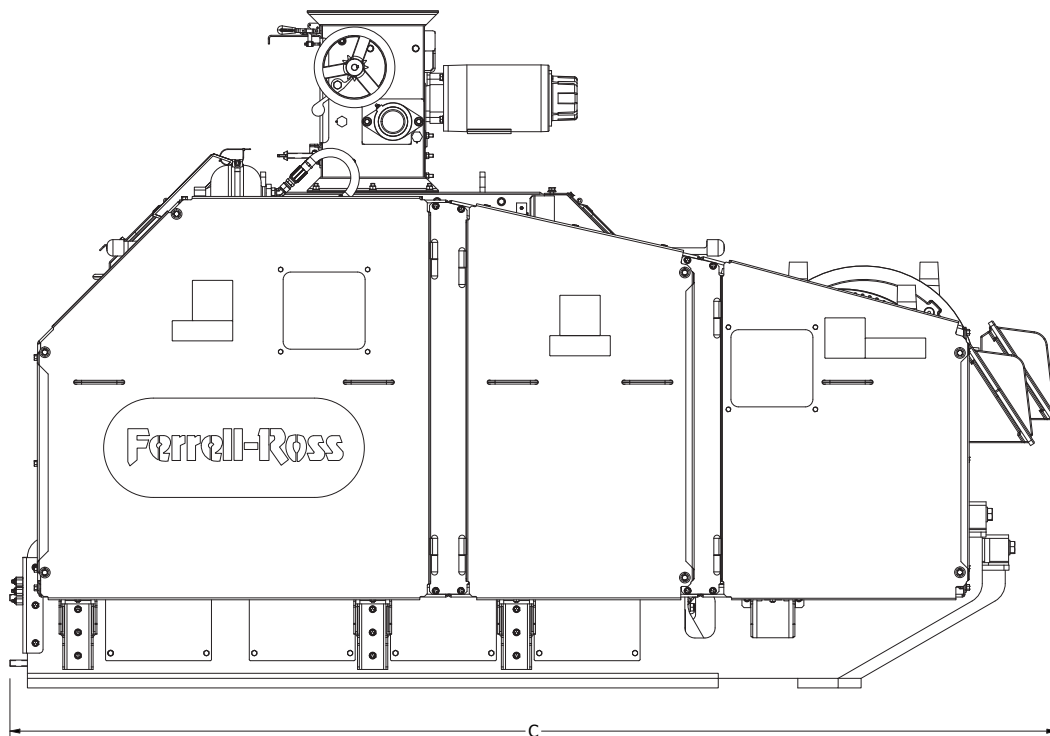
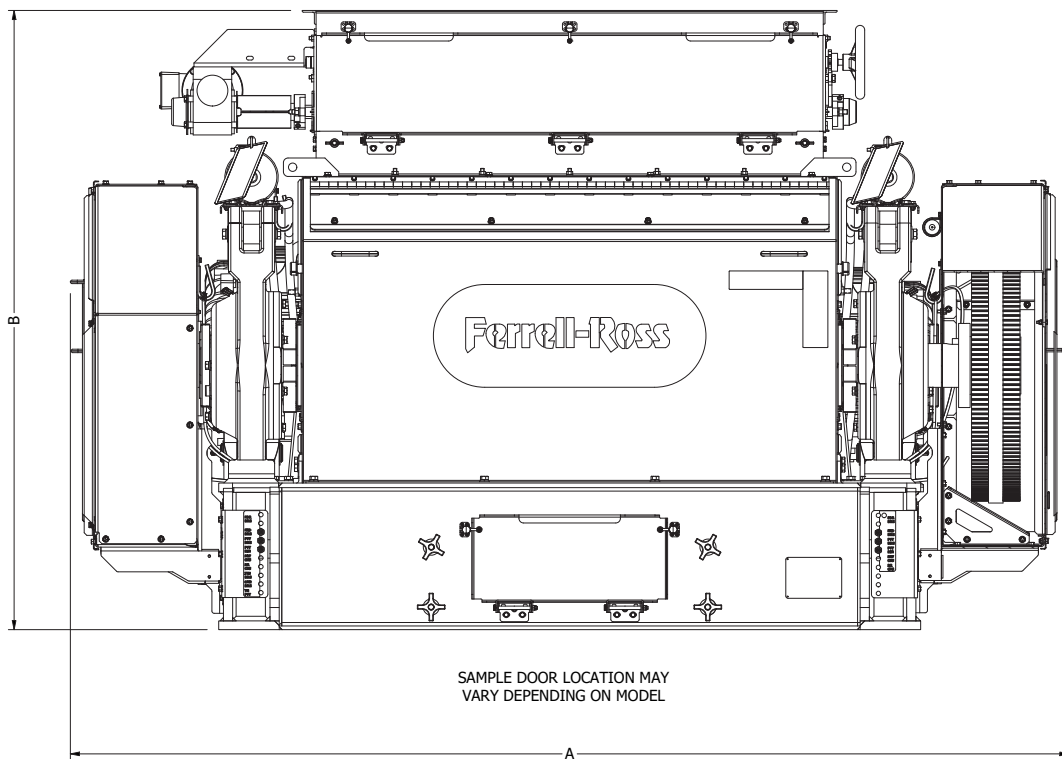

PINNACLE SERIES			
(in)	A	B	C
24X56	108	67	104
32X68	130	74	131

PINNACLE SERIES			
(mm)	A	B	C
24X56	2751	1706	2636
32X68	3306	1878	3319

Precision Milling Solutions for Every Process

1440 South Adams Street, Bluffton, IN 46714 USA (260) 824-3400 (800) 248-8318 Fax (260) 824-5463

E-mail sales@atferrell.com Web www.atferrell.com

Get the factory-authorized parts you need. Call us today.