

REV	ECN	REVISION HISTORY	DATE	APPROVED
A	XXXXXX	RELEASE	5/9/1957	DR
B	F120091	REDRAWN CAD, WAS C SIZE GROUP DRAWING	9/13/2012	dmjohnson
C	F130052	ROTATE ROCKER CUP 30 DEG	4/5/2013	dmjohnson

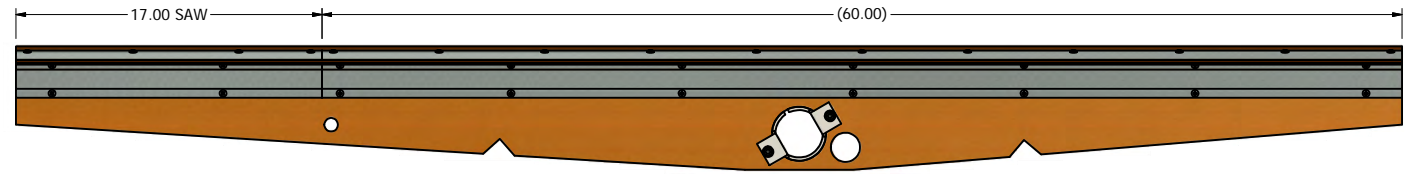

STEP 2: RIGHT ROCKER SIDE ASSEMBLY, LEFT SIDE VIEW
 TYPICAL ASSEMBLY FOR LEFT ROCKER SIDE

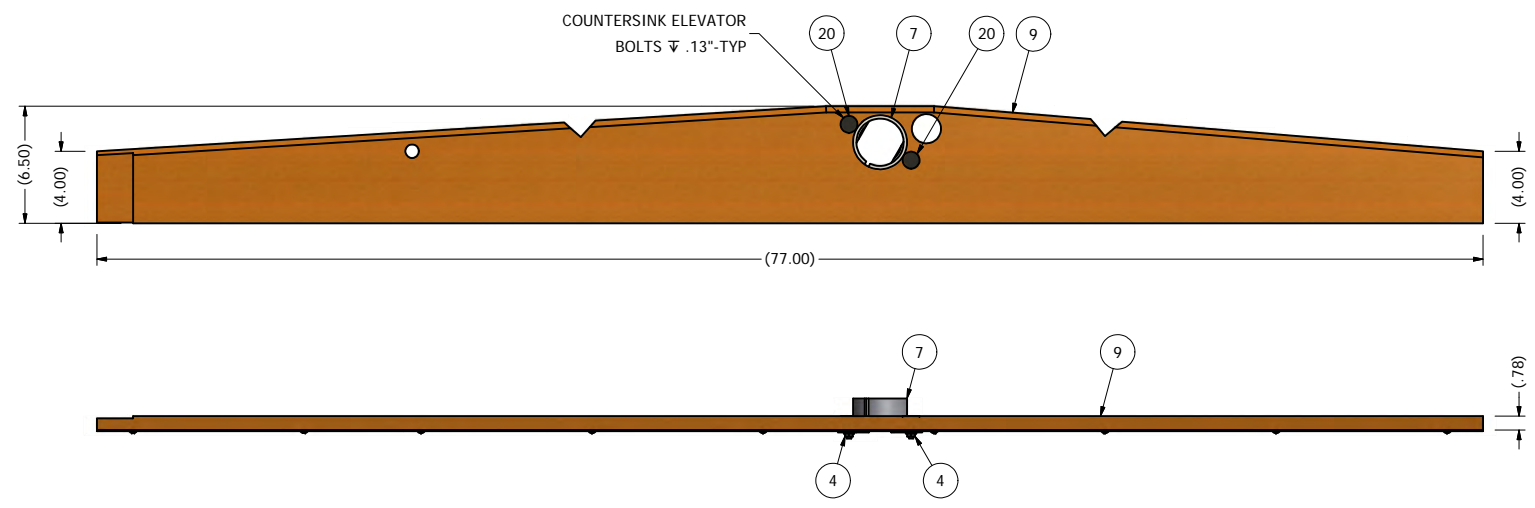

STEP 1: RIGHT ROCKER SIDE ASSEMBLY, LEFT SIDE VIEW
 TYPICAL ASSEMBLY FOR LEFT ROCKER SIDE

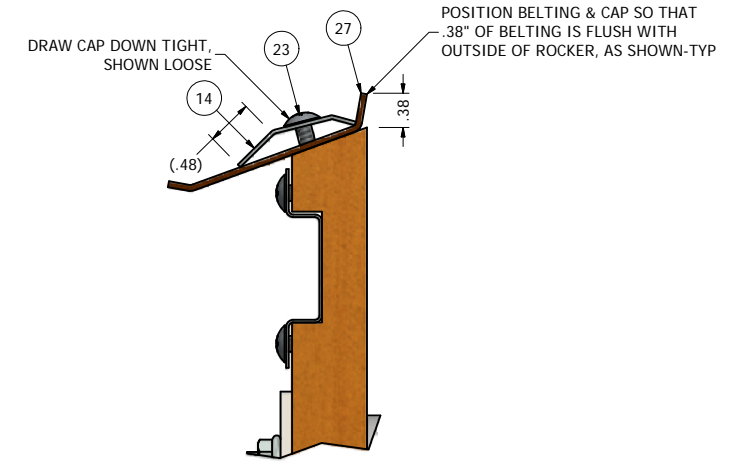

DETAIL B
 SCALE 1:1

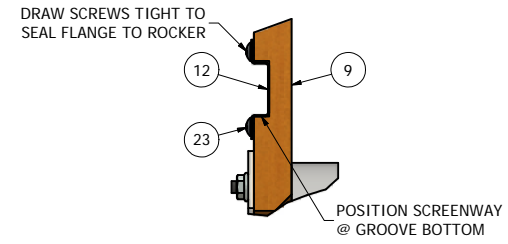

DETAIL A
 SCALE 1/2

ITEM	PART NUMBER	QTY	DESCRIPTION
27	F91152006	13.167 ft	BELTING, 3 PLY FSXFS 2.50 X 79.00"
26	F90005100	1	GIRT WLDMT, ROCKER ADJUSTMENT, CENTERED, #8
25	F84212122	8	SMS, FLT X HD #8 X 3/4"
24	F83453403	4	SMS, PAN X HD, #10 X 3/4"
23	F83453402	86	SMS, PAN X HD, #8 X 3/4"
22	F83451201	7	SMS, PAN X HD, #8 X 1/2"
21	F83440301	4	SMS, FLAT CROSS HEAD #10 X 1.50"
20	F82021407	4	BOLT, ELEV 1/4-20 X 1.25"
19	F11302510	1	COVER, APRON, ADJ GIRT, ROCKER, #8
18	F11302498	1	MOUNT, APRON, ROCKER, #8
17	F03806000	2	ANGLE, SCREEN STOP, ROCKER
16	F03803301	1	BLANK ASSY, TOP ROCKER, BTM SHOE, SX298D
15	F03803201	1	BOTTOM METAL ASSY, TOP RKR, BTM SHOE, SX298D
14	F03801100	2	CAP, RUBBER HOLDING, ROCKER, 60.00"
13	F03801100	2	CAP, RUBBER HOLDING, ROCKER, 17.00"
12	F03800401	2	LINER WLDMT, SCREENWAY, ROCKER, 77.00"
11	F03800002	2	BRACE, BOTTOM, ROCKER, #8
10	F03601502	1	SIDE, LH, TOP ROCKER, BTM SHOE, SX29D/SX298D
9	F03601500	1	SIDE, RH, TOP ROCKER, BTM SHOE, SX29D/SX298D
8	F03500800	2	SCREEN HOOK ASSY, STANDARD
7	F03500600	2	CUP WLDMT, ROCKER, HEAVY DUTY BRUSH
6	F03310009	1	GRAIN STOP ASSY, ROCKER, 2.50" X #8
5	70010521	6	SCW, DECK FLT HD #6 X 2.00"
4	66783300	4	NUT, HEX SERR LOCK 1/4-20
3	66782600	6	NUT, HEX SERR LOCK 10-24
2	66402200	7	WASHER, FLAT, #8
1	60282626	6	BOLT, CARR 10-24 X 1.25"

	DIVISION OF A.T.FERRELL COMPANY 1440 S ADAMS ST BLUFFTON, INDIANA 46714 - USA PH: 260-824-3400 FAX: 260-824-5463	This drawing is the property of the A.T. Ferrell Company, Inc and must be returned immediately upon request. No part of this drawing may be reproduced, stored in a retrieval system or transmitted in any form or by any means, without prior written consent of the A.T. Ferrell Company, Inc.
	DRAWN BY: dmjohnson DRAWN DATE: 9/11/2012 APPROVED BY: DMJ	
TOLERANCES EXCEPT AS NOTED DECIMAL: .030 FRACTIONAL: 1/32 XX ± .030 XXX ± .005 XXXX ± .001	TITLE: ROCKER ASSY, TOP, BOTTOM SHOE, SX298D	
CAD NO MANUAL CHANGES	SCALE: 0.19:1 SHEET: 1 OF 3 SIZE: D PART NUMBER: F03501910	REV: C

NOTES:
 1. DO NOT SCALE FROM DRAWING.
 2. ONE PIECE REQUIRED PER F03018407/08: SHOE ASSY, RH/LH ADJ PITCH BOTTOM, SX298D.

REV	ECN	REVISION HISTORY	DATE	APPROVED
A	XXXXXX	RELEASE	5/9/1957	DR
B	F120091	REDRAWN CAD, WAS C SIZE GROUP DRAWING	9/13/2012	dmjohnson
C	F130052	ROTATE ROCKER CUP 30 DEG	4/5/2013	dmjohnson

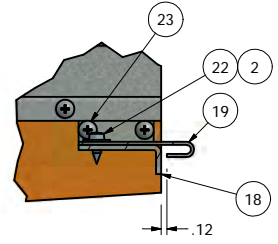
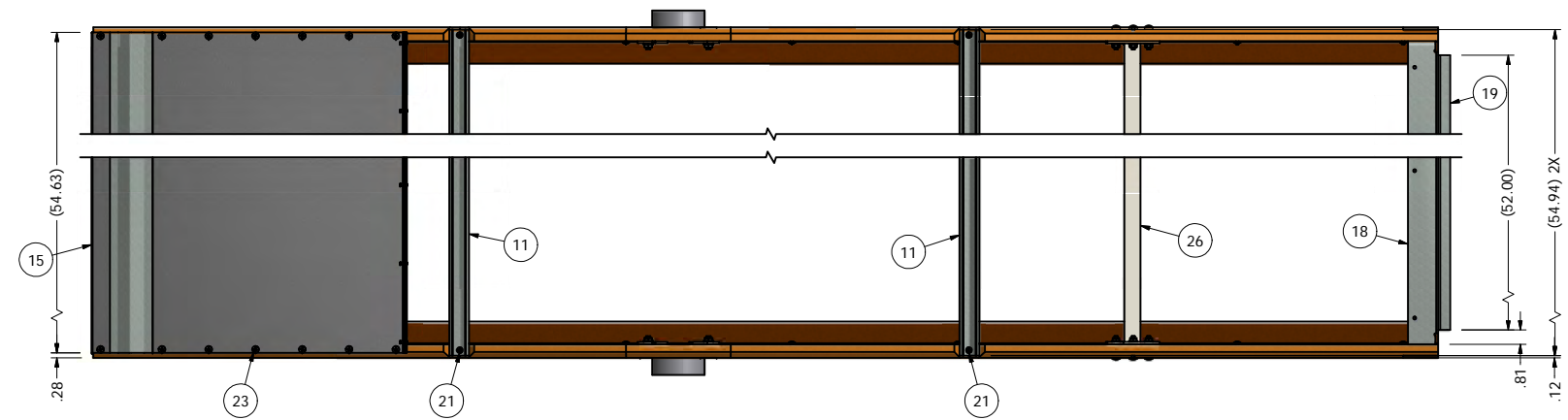

DETAIL F
SCALE 1/2

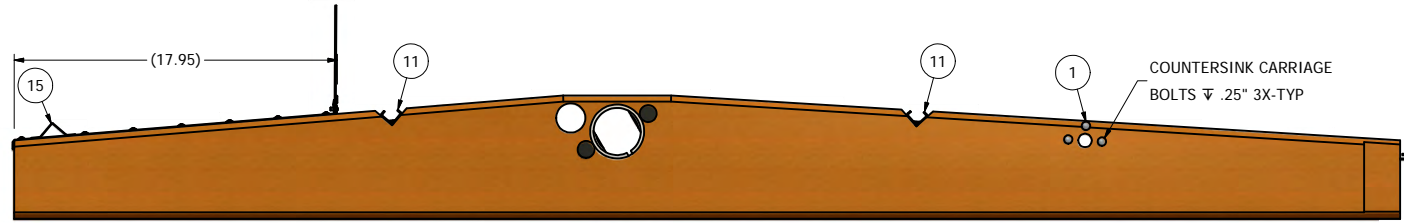
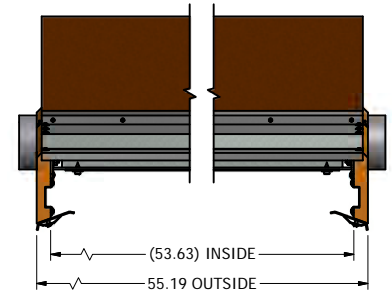

USE Ø.75" ROUND ROD TO ALIGN SIDES & GIRT

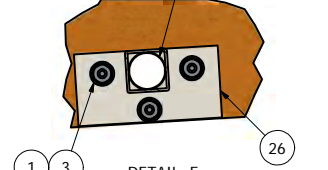

DETAIL E
SCALE 1/2

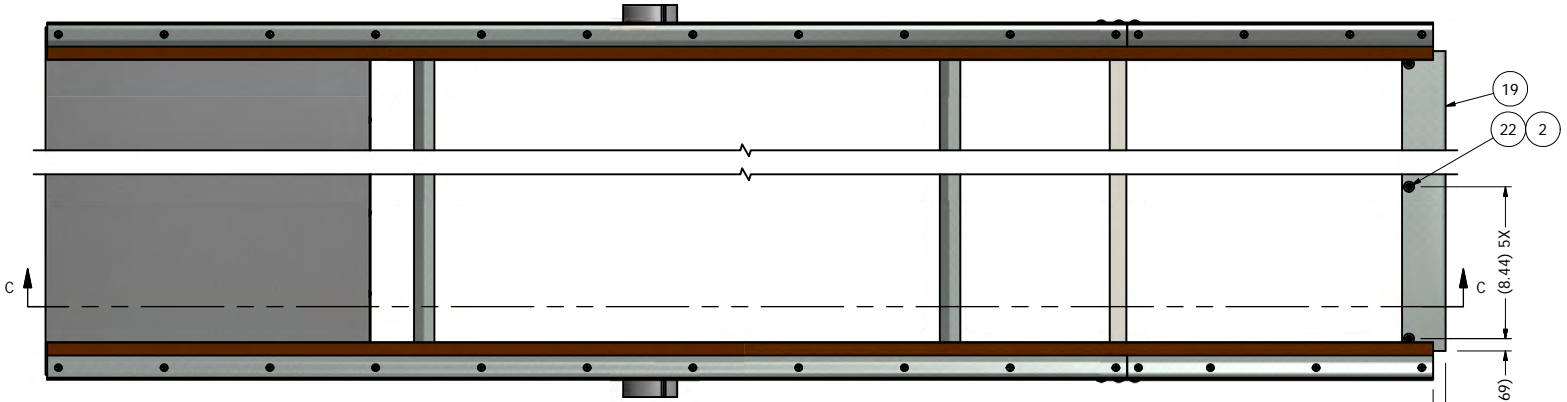

STEP 3: GIRT INSTALLATION, TOP VIEW

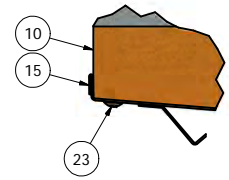

DETAIL D
SCALE 1/2

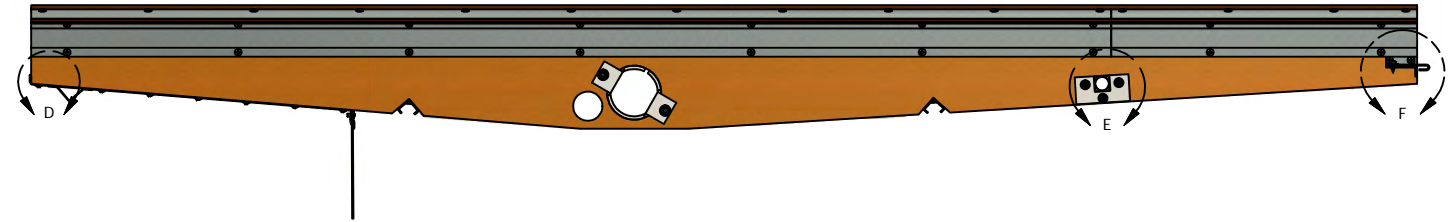

SECTION C-C

ITEM	PART NUMBER	QTY	DESCRIPTION
27	F91152006	13.167 ft	BELTING, 3 PLY FSXFS 2.50 X 79.00"
26	F90005100	1	GIRT WLDMT, ROCKER ADJUSTMENT, CENTERED, #8
25	F84212122	8	SMS, FLT X HD #8 X 3/4"
24	F83453403	4	SMS, PAN X HD, #10 X 3/4"
23	F83453402	86	SMS, PAN X HD, #8 X 3/4"
22	F83451201	7	SMS, PAN X HD, #8 X 1/2"
21	F83440301	4	SMS, FLAT CROSS HEAD #10 X 1.50"
20	F82021407	4	BOLT, ELEV 1/4-20 X 1.25"
19	F11302510	1	COVER, APRON, ADJ GIRT, ROCKER, #8
18	F11302498	1	MOUNT, APRON, ROCKER, #8
17	F03806000	2	ANGLE, SCREEN STOP, ROCKER
16	F03803301	1	BLANK ASSY, TOP ROCKER, BTM SHOE, SX298D
15	F03803201	1	BOTTOM METAL ASSY, TOP RKR, BTM SHOE, SX298D
14	F03801100	2	CAP, RUBBER HOLDING, ROCKER, 60.00"
13	F03801100	2	CAP, RUBBER HOLDING, ROCKER, 17.00"
12	F03800401	2	LINER WLDMT, SCREENWAY, ROCKER, 77.00"
11	F03800002	2	BRACE, BOTTOM, ROCKER, #8
10	F03601502	1	SIDE, LH, TOP ROCKER, BTM SHOE, SX29D/SX298D
9	F03601500	1	SIDE, RH, TOP ROCKER, BTM SHOE, SX29D/SX298D
8	F03500800	2	SCREEN HOOK ASSY, STANDARD
7	F03500600	2	CUP WLDMT, ROCKER, HEAVY DUTY BRUSH
6	F03310009	1	GRAIN STOP ASSY, ROCKER, 2.50" X #8
5	70010521	6	SCW, DECK FLT HD #6 X 2.00"
4	66783300	4	NUT, HEX SERR LOCK 1/4-20
3	66782600	6	NUT, HEX SERR LOCK 10-24
2	66402200	7	WASHER, FLAT, #8
1	60282626	6	BOLT, CARR 10-24 X 1.25"

CLIPPER SEPARATION TECHNOLOGIES SINCE 1888

DIVISION OF A.T. FERRELL COMPANY
 1440 S ADAMS ST
 BLUFFTON, INDIANA 46714 - USA
 PH: 260-824-3400
 FAX: 260-824-5463

This drawing is the property of the A.T. Ferrell Company, Inc. and must be returned immediately upon request. No part of this drawing may be reproduced, stored in a retrieval system or transmitted in any form or by any means, without prior written consent of the A.T. Ferrell Company, Inc.

DRAWN BY: dmjohnson
 DRAWN DATE: 9/11/2012
 APPROVED BY: DMJ

TOLERANCES EXCEPT AS NOTED	TITLE
DECIMAL: XX ± .030	ROCKER ASSY, TOP, BOTTOM SHOE, SX298D
FRACTIONAL: XXX ± .005	
ANGULAR: XXXX ± .001	
	FINISH: NONE
	ANGULAR: ± 1/2°

CAD	NO MANUAL CHANGES	SCALE: 0.19:1	SHEET: 2 OF 3	SIZE: D	PART NUMBER: F03501910	REV: C
------------	-------------------	---------------	---------------	---------	------------------------	--------

NOTES:
 1. DO NOT SCALE FROM DRAWING.
 2. ONE PIECE REQUIRED PER F03018407/08: SHOE ASSY, RH/LH ADJ PITCH BOTTOM, SX298D.

REV	ECN	REVISION HISTORY	DATE	APPROVED
A	XXXXXX	RELEASE	5/9/1957	DR
B	F120091	REDRAWN CAD, WAS C SIZE GROUP DRAWING	9/13/2012	dmjohnson
C	F130052	ROTATE ROCKER CUP 30 DEG	4/5/2013	dmjohnson

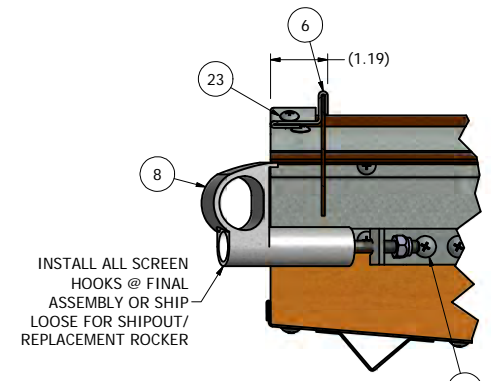
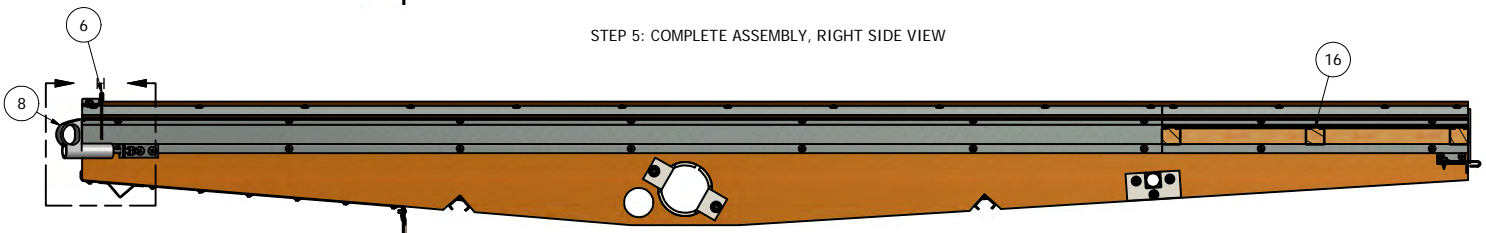
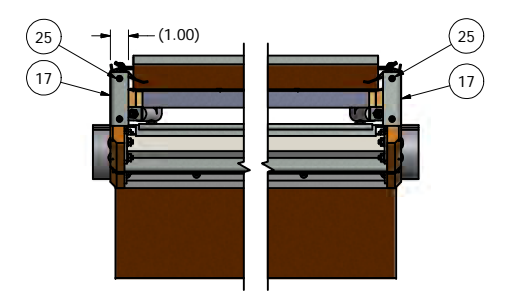
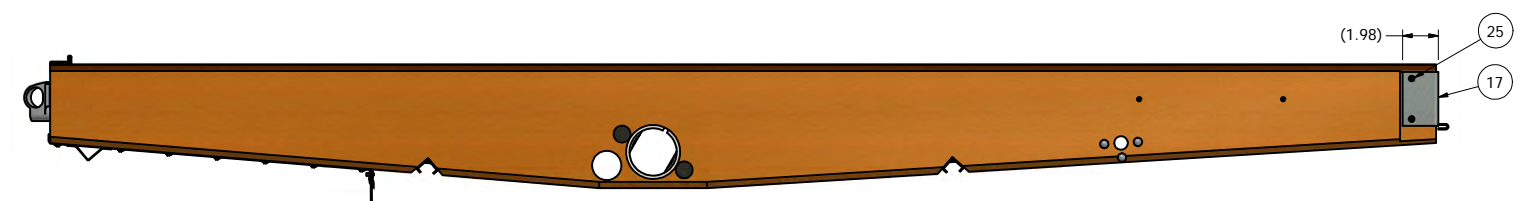
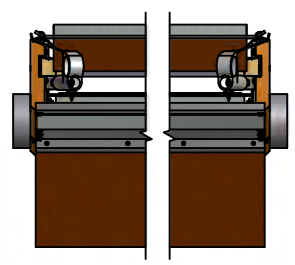
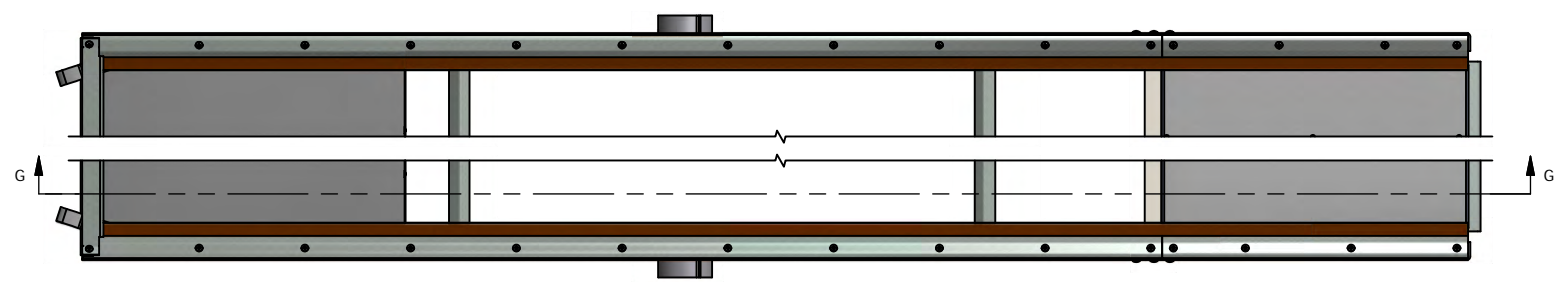

INSTALL ALL SCREEN HOOKS @ FINAL ASSEMBLY OR SHIP LOOSE FOR SHIPOUT/REPLACEMENT ROCKER

DETAIL H SCALE 1/2

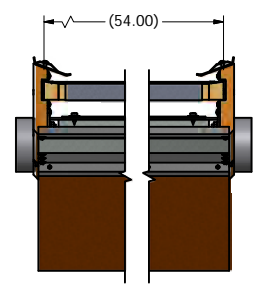
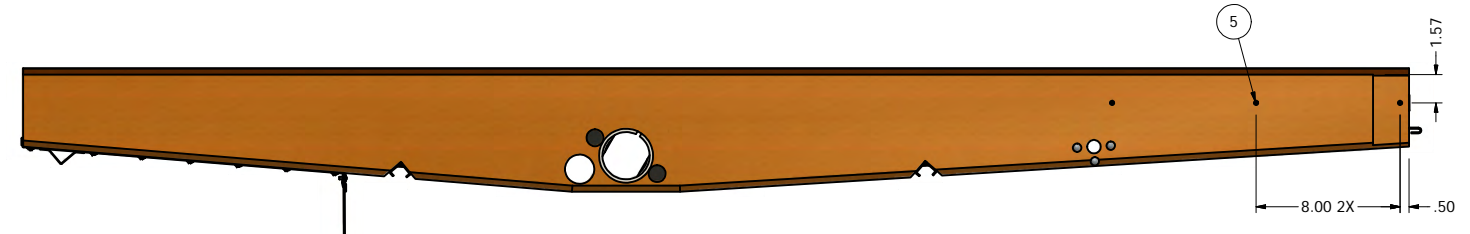
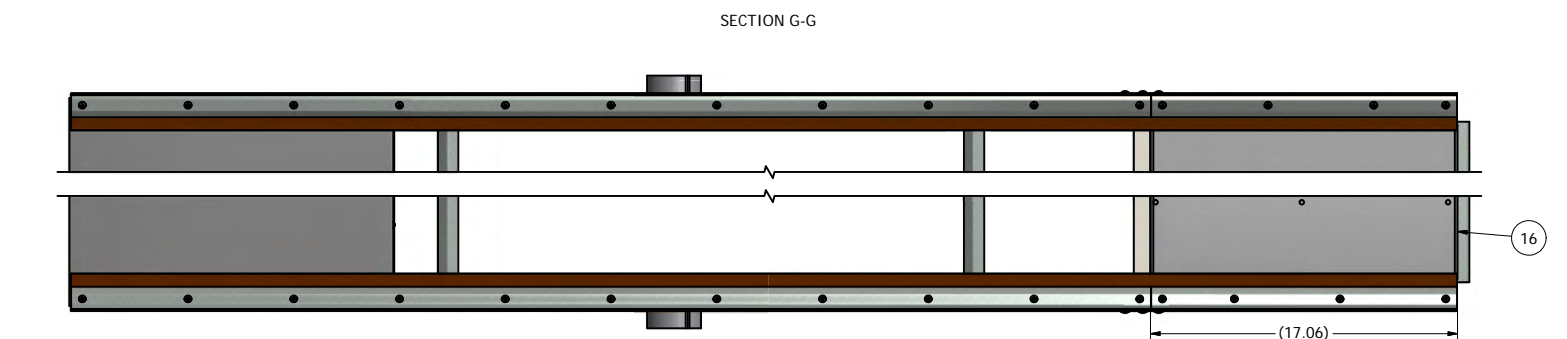

ITEM	PART NUMBER	QTY	DESCRIPTION
27	F91152006	13.167 ft	BELTING, 3 PLY FSXFS 2.50 X 79.00"
26	F90005100	1	GIRT WLDMT, ROCKER ADJUSTMENT, CENTERED, #8
25	F84212122	8	SMS, FLT X HD #8 X 3/4"
24	F83453403	4	SMS, PAN X HD, #10 X 3/4"
23	F83453402	86	SMS, PAN X HD, #8 X 3/4"
22	F83451201	7	SMS, PAN X HD, #8 X 1/2"
21	F83440301	4	SMS, FLAT CROSS HEAD #10 X 1.50"
20	F82021407	4	BOLT, ELEV 1/4-20 X 1.25"
19	F11302510	1	COVER, APRON, ADJ GIRT, ROCKER, #8
18	F11302498	1	MOUNT, APRON, ROCKER, #8
17	F03806000	2	ANGLE, SCREEN STOP, ROCKER
16	F03803301	1	BLANK ASSY, TOP ROCKER, BTM SHOE, SX298D
15	F03803201	1	BOTTOM METAL ASSY, TOP RKR, BTM SHOE, SX298D
14	F03801100	2	CAP, RUBBER HOLDING, ROCKER, 60.00"
13	F03801100	2	CAP, RUBBER HOLDING, ROCKER, 17.00"
12	F03800401	2	LINER WLDMT, SCREENWAY, ROCKER, 77.00"
11	F03800002	2	BRACE, BOTTOM, ROCKER, #8
10	F03601502	1	SIDE, LH, TOP ROCKER, BTM SHOE, SX29D/SX298D
9	F03601500	1	SIDE, RH, TOP ROCKER, BTM SHOE, SX29D/SX298D
8	F03500800	2	SCREEN HOOK ASSY, STANDARD
7	F03500600	2	CUP WLDMT, ROCKER, HEAVY DUTY BRUSH
6	F03310009	1	GRAIN STOP ASSY, ROCKER, 2.50" X #8
5	70010521	6	SCW, DECK FLT HD #6 X 2.00"
4	66783300	4	NUT, HEX SERR LOCK 1/4-20
3	66782600	6	NUT, HEX SERR LOCK 10-24
2	66402200	7	WASHER, FLAT, #8
1	60282626	6	BOLT, CARR 10-24 X 1.25"

NOTES:
 1. DO NOT SCALE FROM DRAWING.
 2. ONE PIECE REQUIRED PER F03018407/08: SHOE ASSY, RH/LH ADJ PITCH BOTTOM, SX298D.

CLIPPER
SEPARATION TECHNOLOGIES

DIVISION OF
A.T.FERRELL COMPANY
 1440 S ADAMS ST
 BLUFFTON, INDIANA
 46714 - USA
 PH: 260-824-3400
 FAX: 260-824-5463

This drawing is the property of the A.T. Ferrell Company, Inc and must be returned immediately upon request. No part of this drawing may be reproduced, stored in a retrieval system or transmitted in any form or by any means, without prior written consent of the A.T. Ferrell Company, Inc.

TOLERANCES EXCEPT AS NOTED	TITLE:
DECIMAL: .030	ROCKER ASSY, TOP, BOTTOM SHOE, SX298D
FRACTIONAL: 1/32	
XX ± .030	FINISH:
XXX ± .005	NONE
XXXX ± .001	ANGULAR: ± 1/2°
CAD NO MANUAL CHANGES	SCALE: 0.19:1
	SHEET: 3 OF 3
	SIZE: D
	PART NUMBER: F03501910
	REV: C