

BLUE PRINT SUPPLY & CO. INC. N.Y.

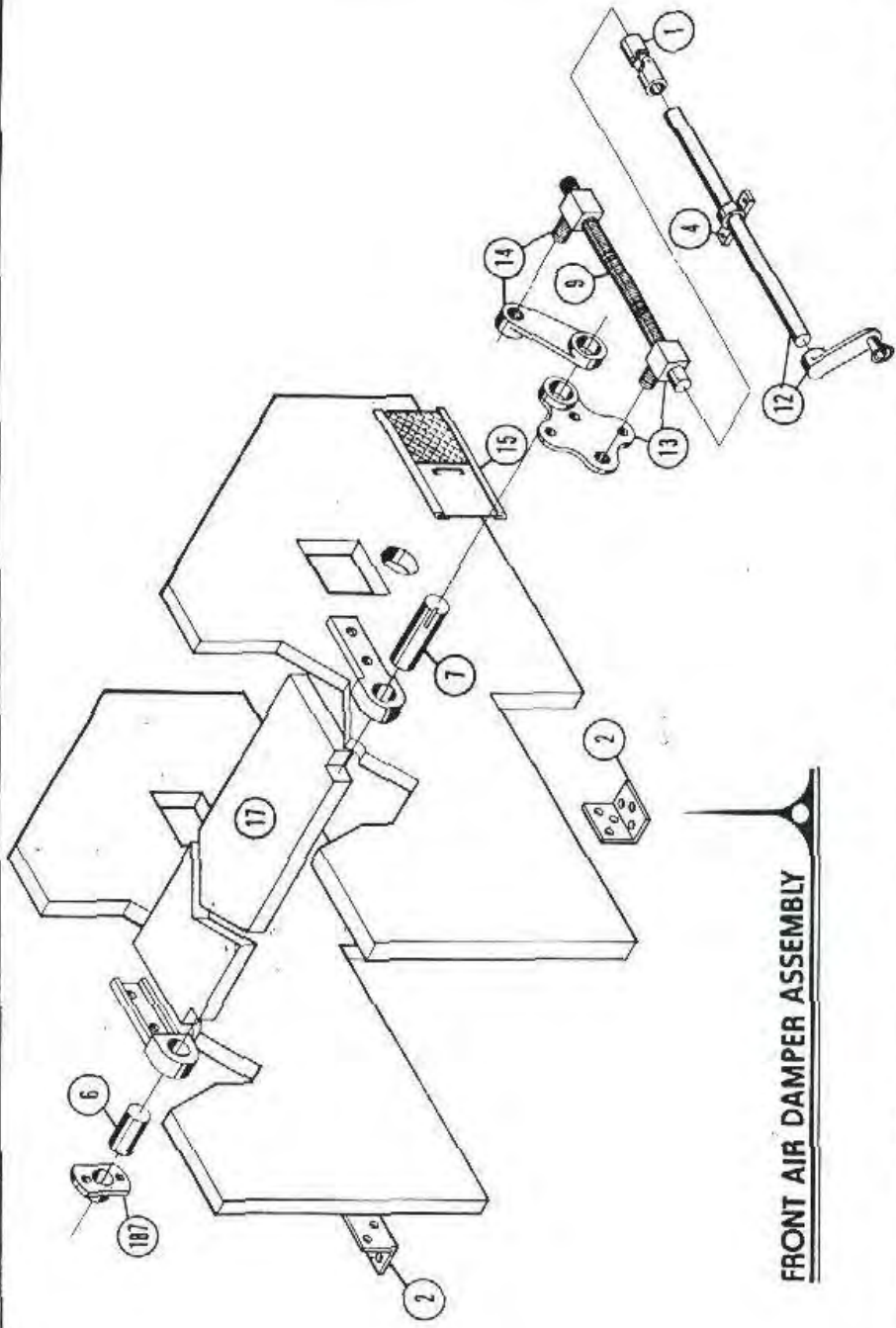

**FRONT AIR DAMPER ASSEMBLY**

SYM		REVISION	DATE	ON	DATE	SCALE	DATE
<b>front air damper assembly</b>							
FERRELL - ROSS				MICH. NO.			
SAGINAW MICH.				DWG. NO.			

BACK AIR DAMPER : TOP FAN SECTION

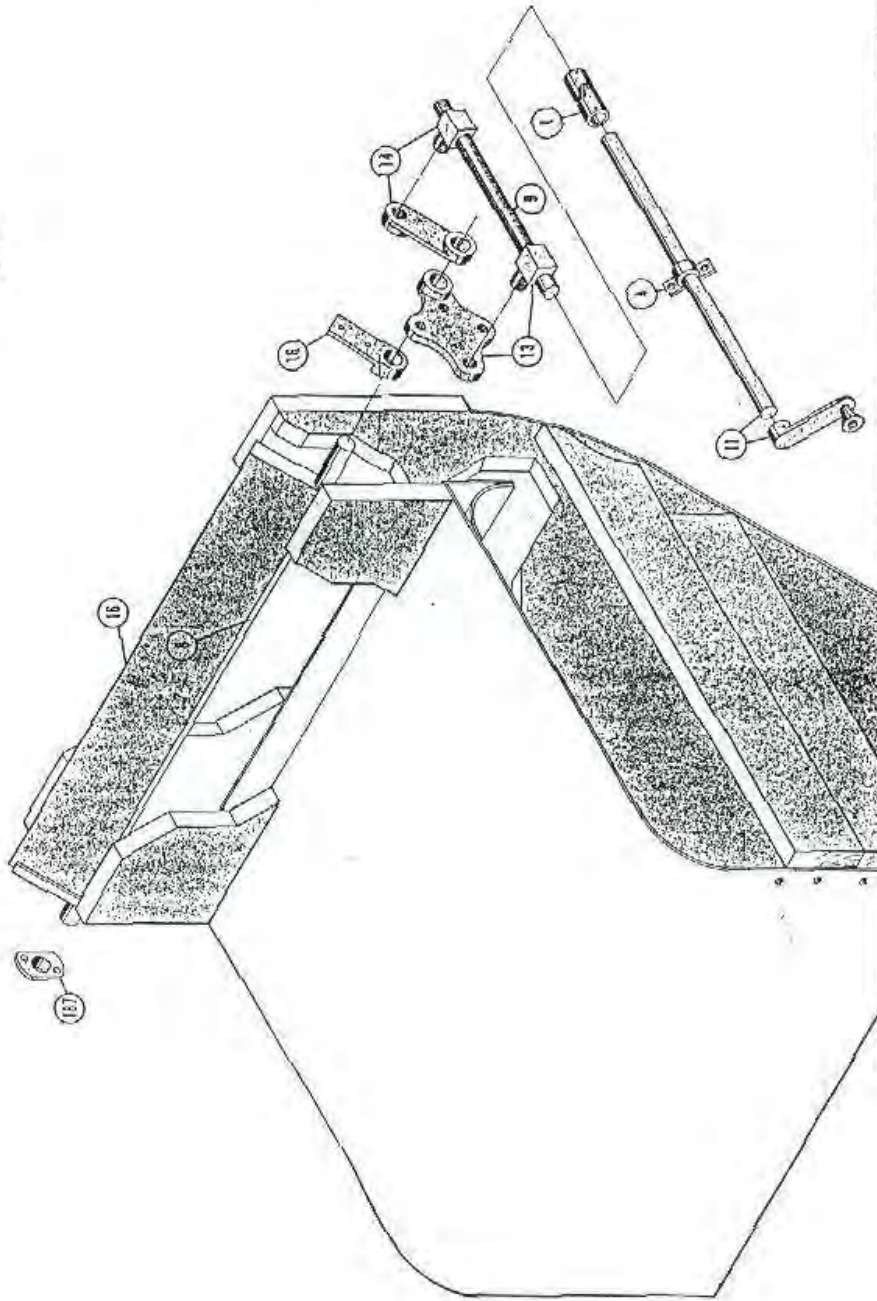

FENNELL - ROSS ENGINEERS & ARCHT.		DATE	BY	CHKD BY
DRAWING NO. BWC 110		APPROVED		
MATERIAL				
REVISIONS				

SCALE: PER NET SUPPLY, V. 100 (10-18-13) 1/4"

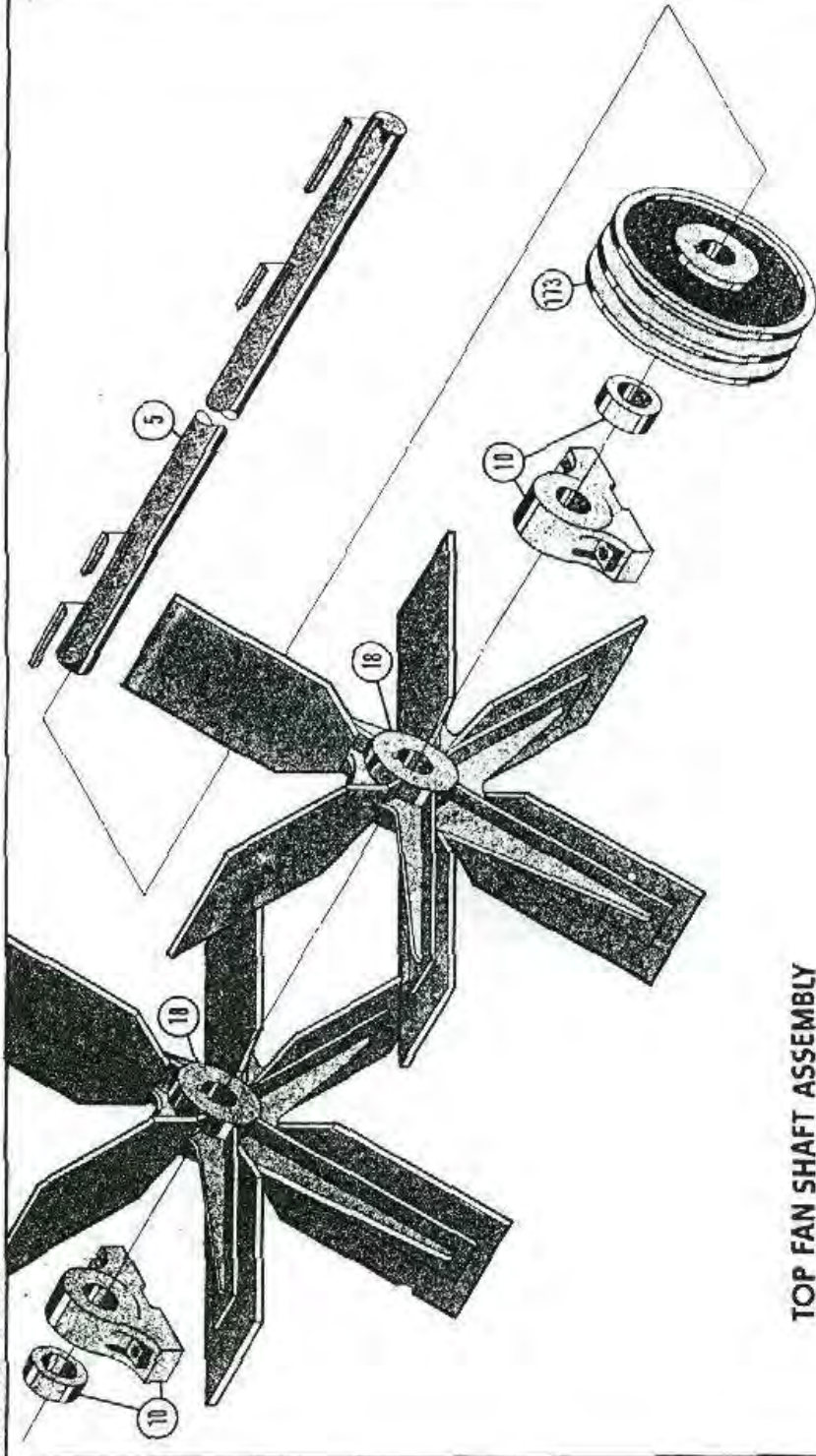

### TOP FAN SHAFT ASSEMBLY

REV.	REVISION	DATE	BY

**top fan shaft assembly**

DESIGNED BY: J.S.E.    SCALE: 0-28-77    DATE:   

FERRELL - ROSS  
SAGINAW, MICH.  
DWG. NO.    MACH. NO.



MULTI-PHASE SUPPLY - 2500 1/2" x 11 1/2"

# TOP AIR DISCHARGE ARRANGEMENT

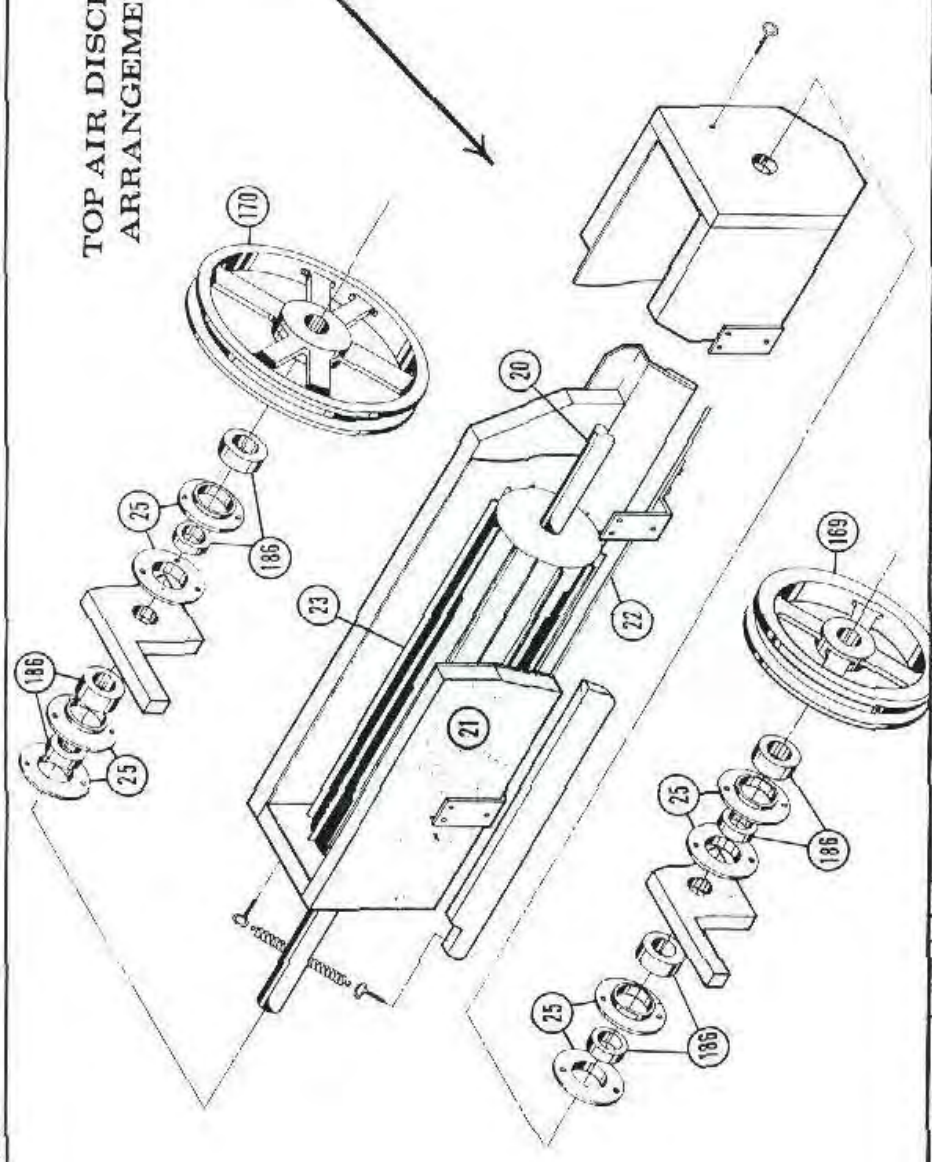

SYN.	REV.	DATE	BY	DATE	SCALE	DRAWN BY	J. B.	DATE	2-10-17	DWG. NO.		MACH. NO.	
<b>- top air discharge arrangement</b>													
FERRELL - ROSS													
SAGINAW, MICH.													

5

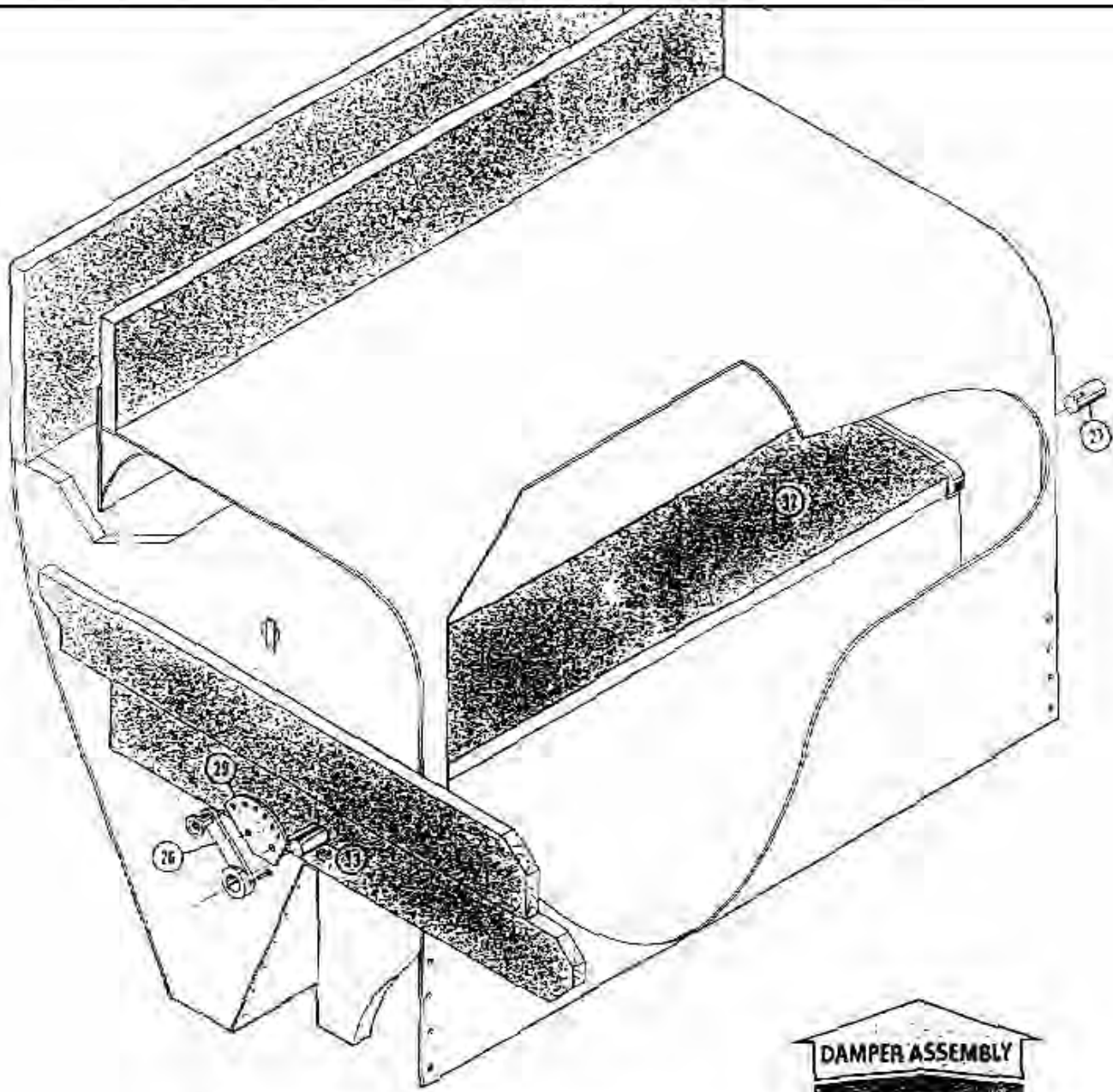

**DAMPER ASSEMBLY**

REV	DATE	BY	CHKD	APP'D	DESCRIPTION	FERRELL - ROSS	WORK NO.
					damper assembly	WATER WHEEL	
						DWR NO.	

6

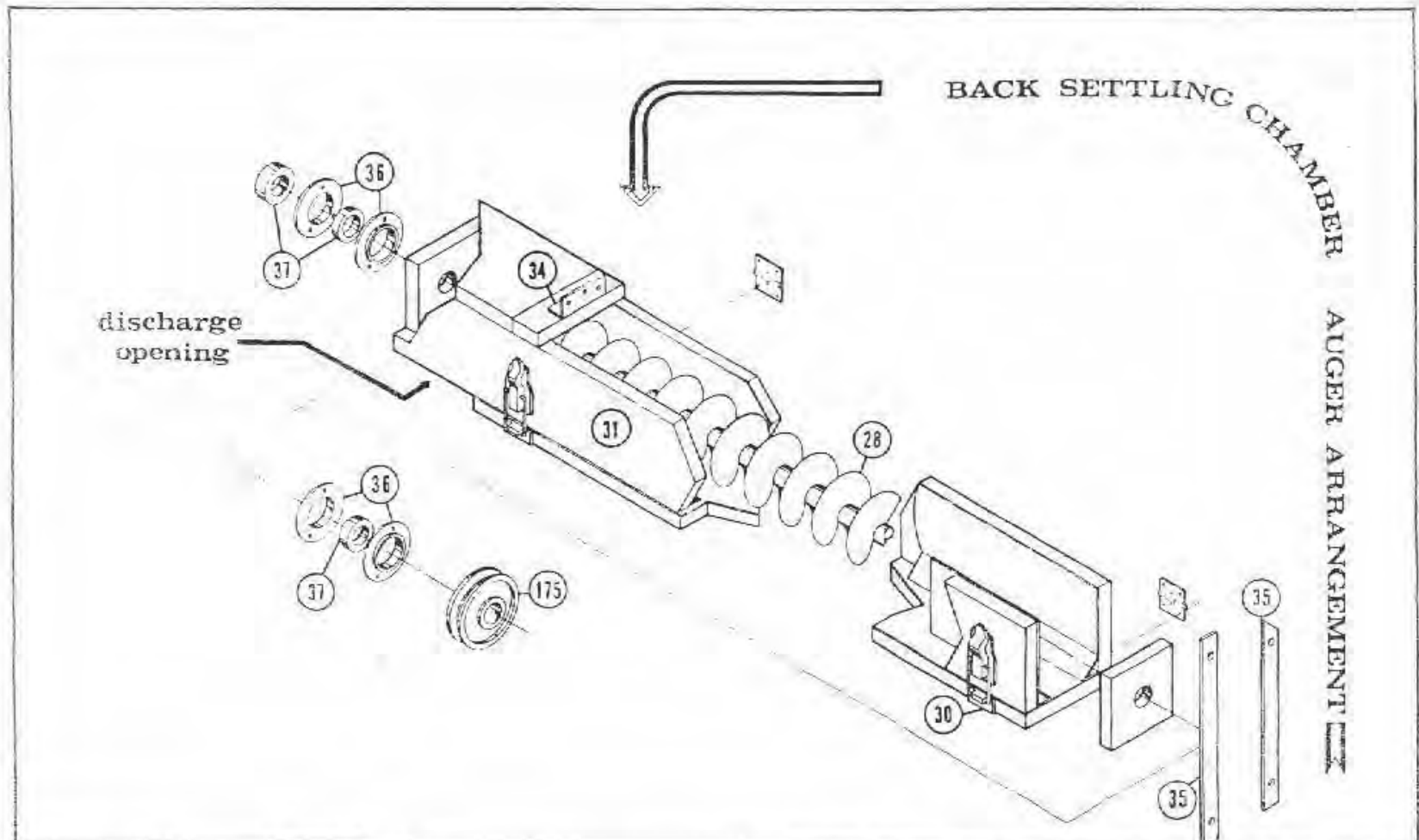

REV	REVISION	DATE	BY	CHKD	APP'D	<b>back settling chamber auger arrangement</b>	<b>FERRELL - ROSS</b> SAGINAW MICH.	MACH NO.
						DWN BY JDS	SCALE	DATE 12-28-72

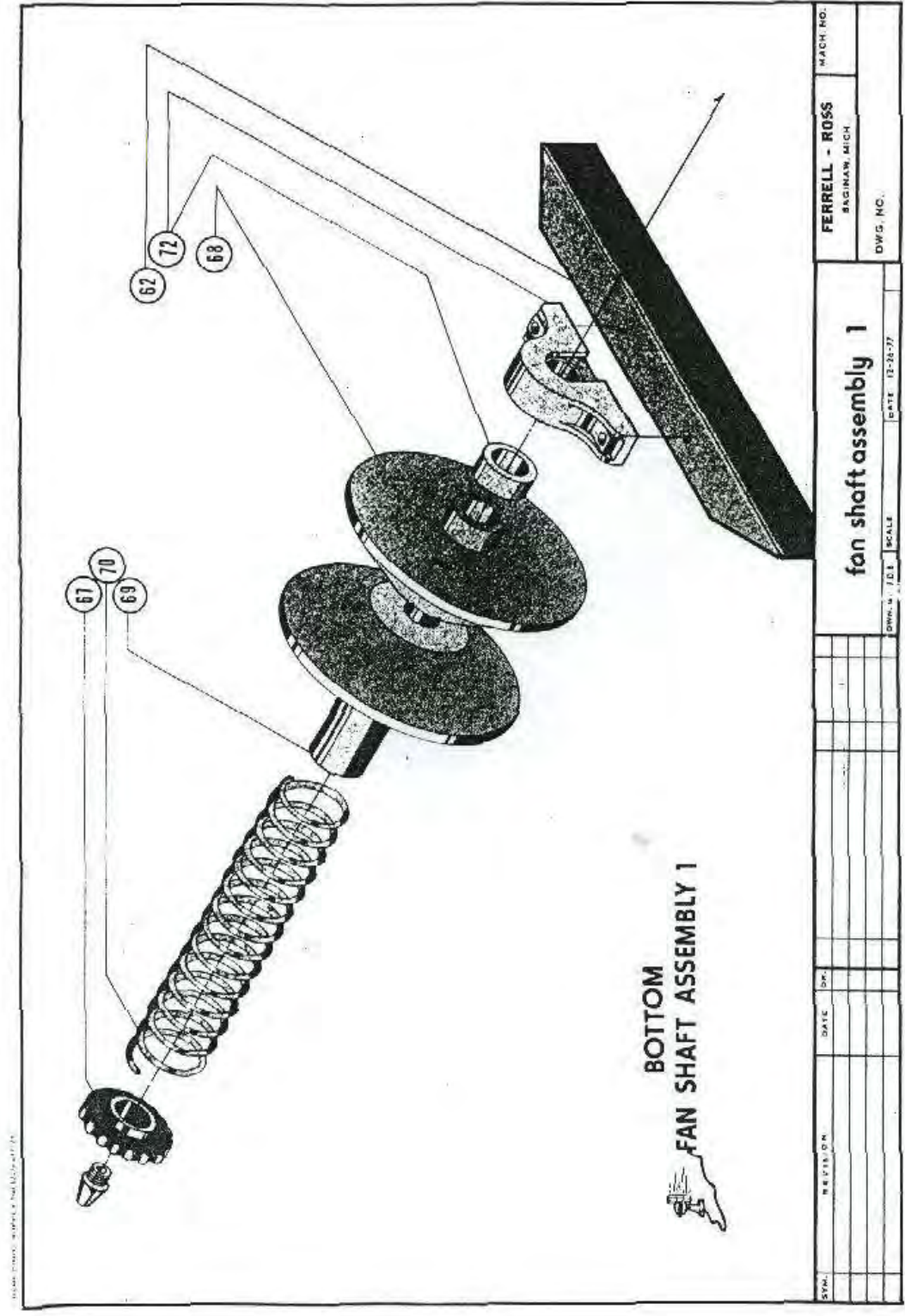

SYM.	REVISION	DATE	BY		SCALE	DATE	13-20-77
					DWG. NO. J.O.I.	DWS. NO.	MACH. NO.



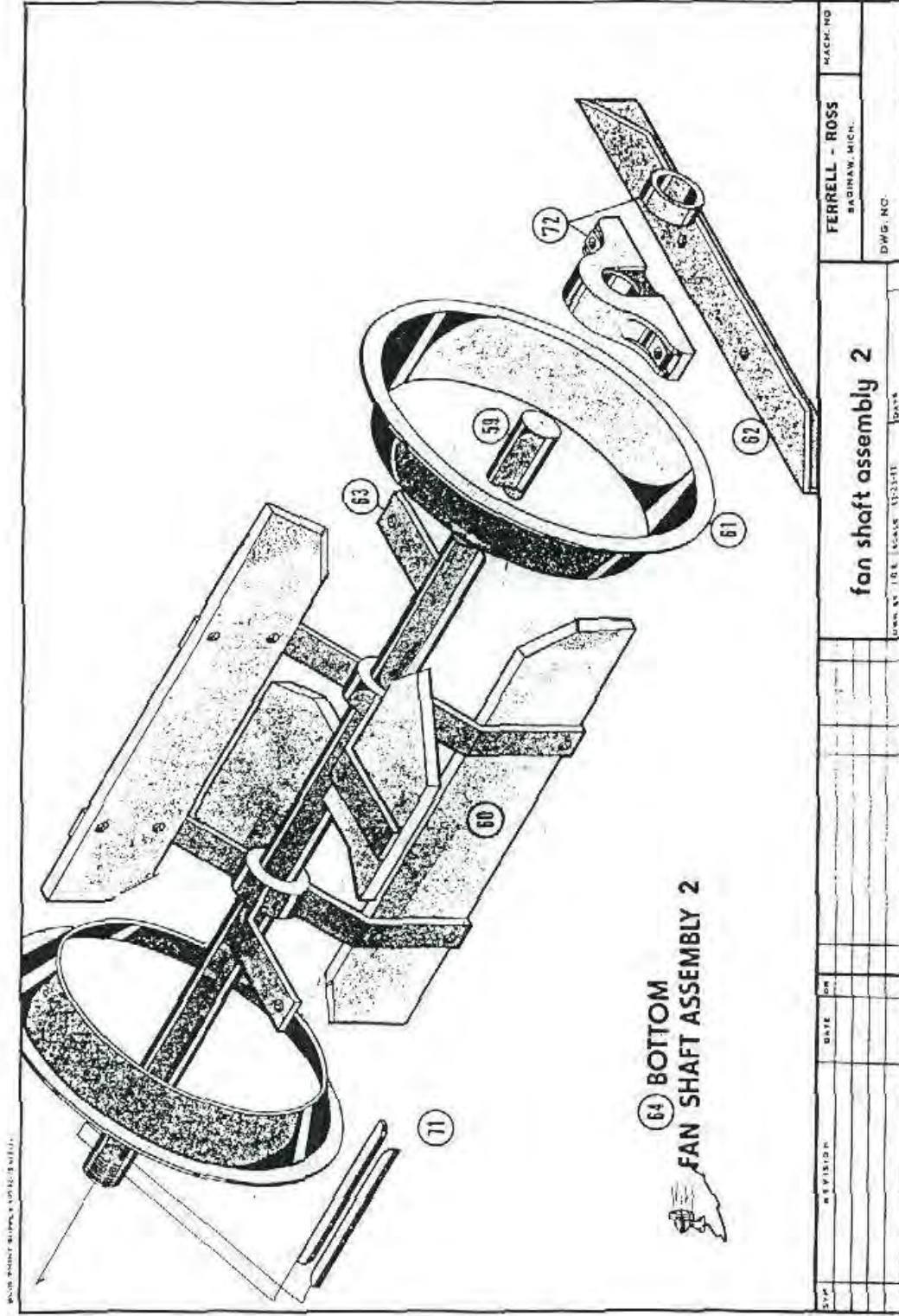

DO NOT REMOVE WEIGHTS & COUNTER WEIGHTS

**64** BOTTOM  
FAN SHAFT ASSEMBLY 2

MACH. NO.		
FERRELL - ROSS		
SAGINAW, MICH.		
DWG. NO.		
fan shaft assembly 2		DATE
DATE	REVISION	BY





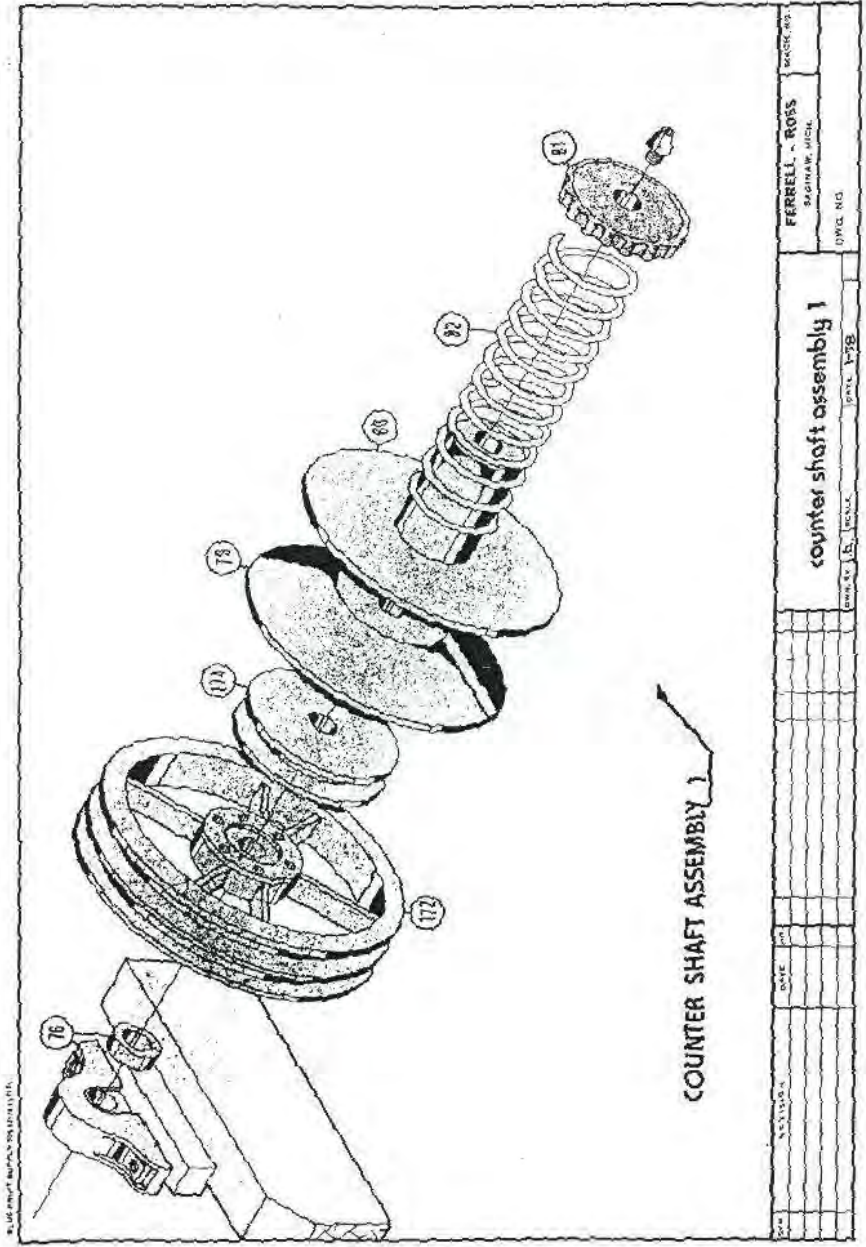

COUNTER SHAFT ASSEMBLY 1

DATE	BY	CHKD	APP'D	REV

FERRELL - ROSS  
SAGINAW, MICH.  
DWG. NO.

counter shaft assembly 1  
DATE: 5-1-58  
DWG. NO.

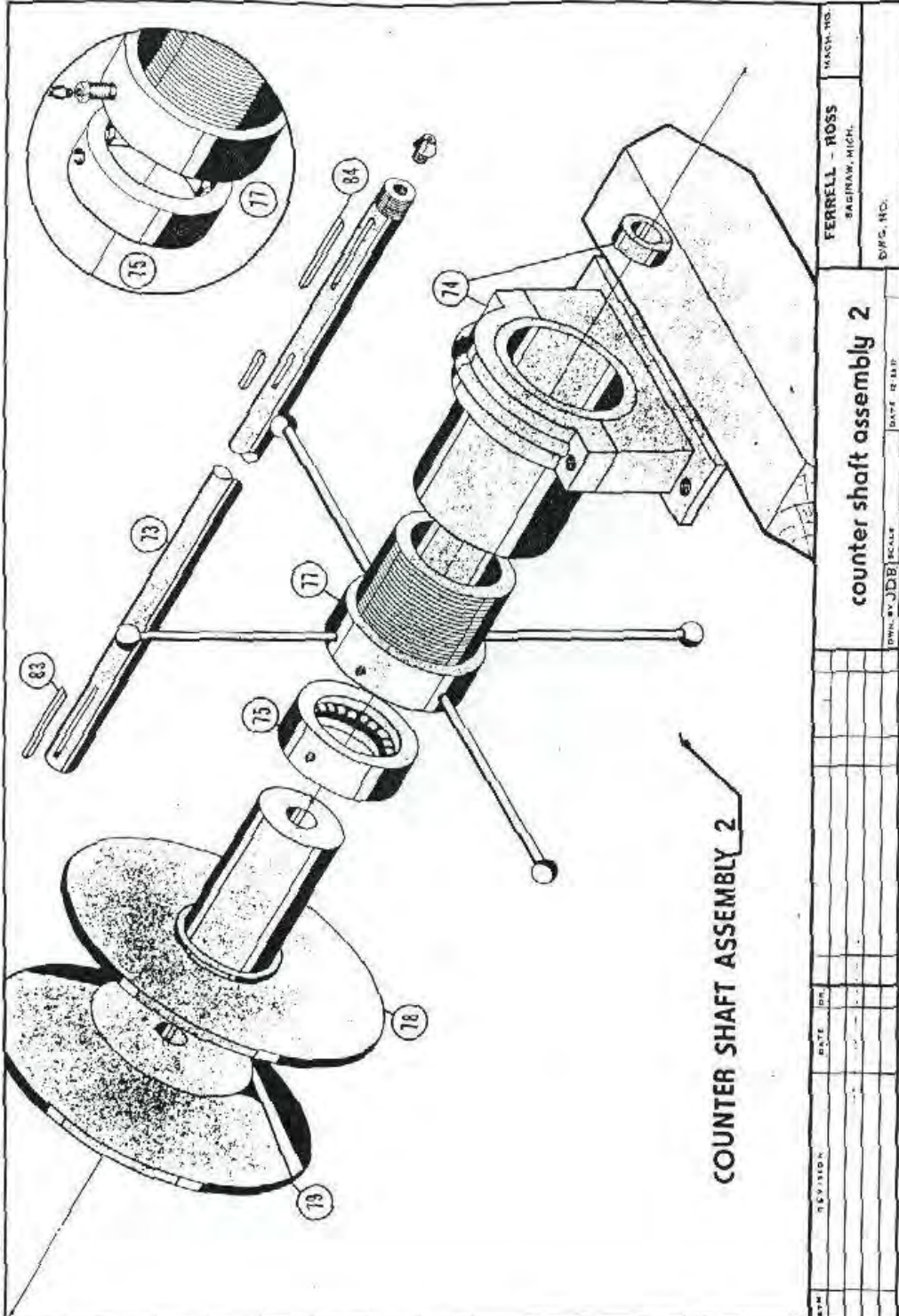

COUNTER SHAFT ASSEMBLY 2

ALL DIMENSIONS UNLESS OTHERWISE NOTED

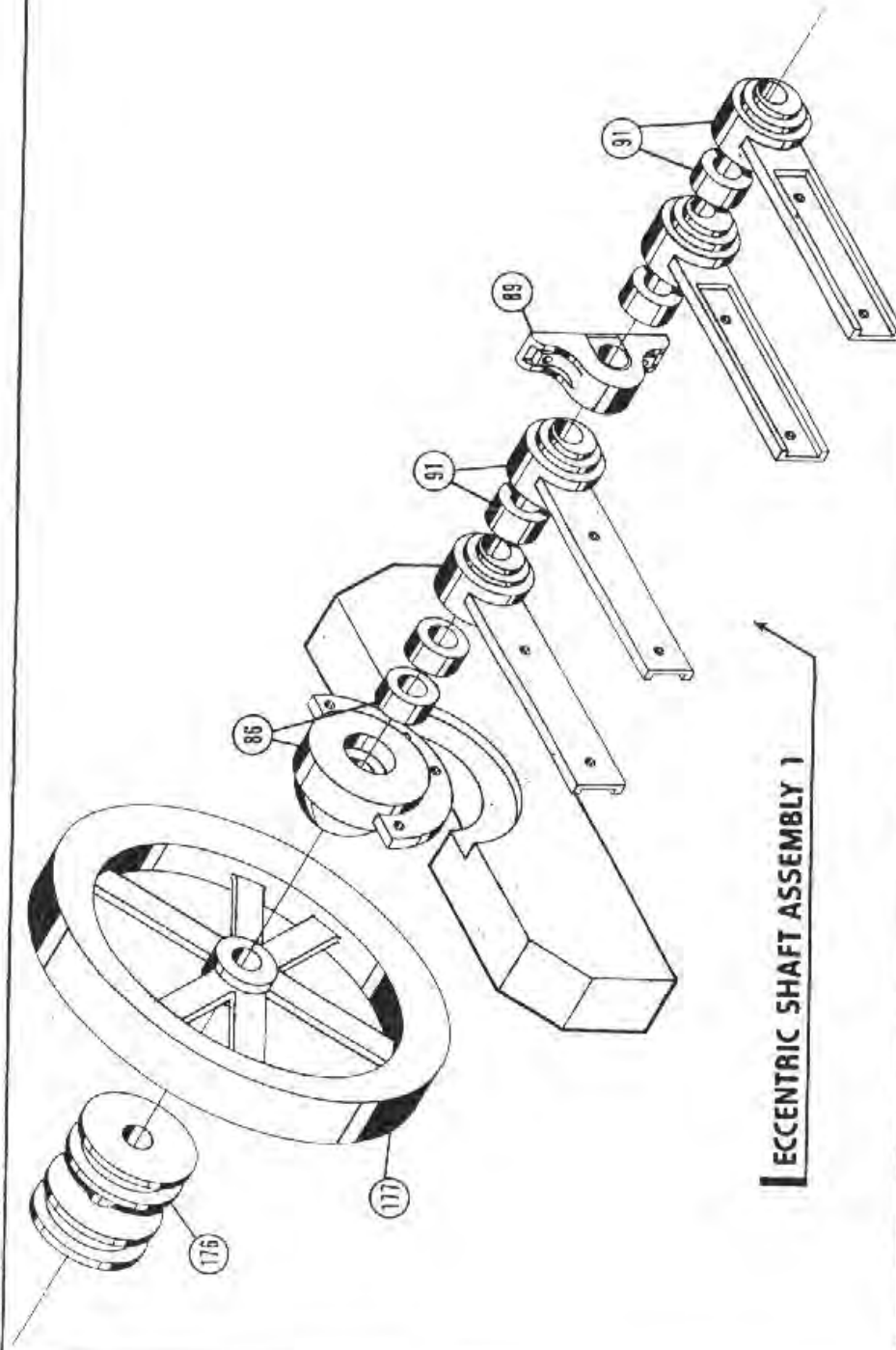

ECCENTRIC SHAFT ASSEMBLY 1

REV	REVISION	DATE	BY	CHKD	SCALE	DATE	DRN BY	SCALE	DATE	FERRELL - ROSS BAGINAW, MICH.	DWG NO.	WACH NO.
										<b>eccentric shaft assembly 1</b>		



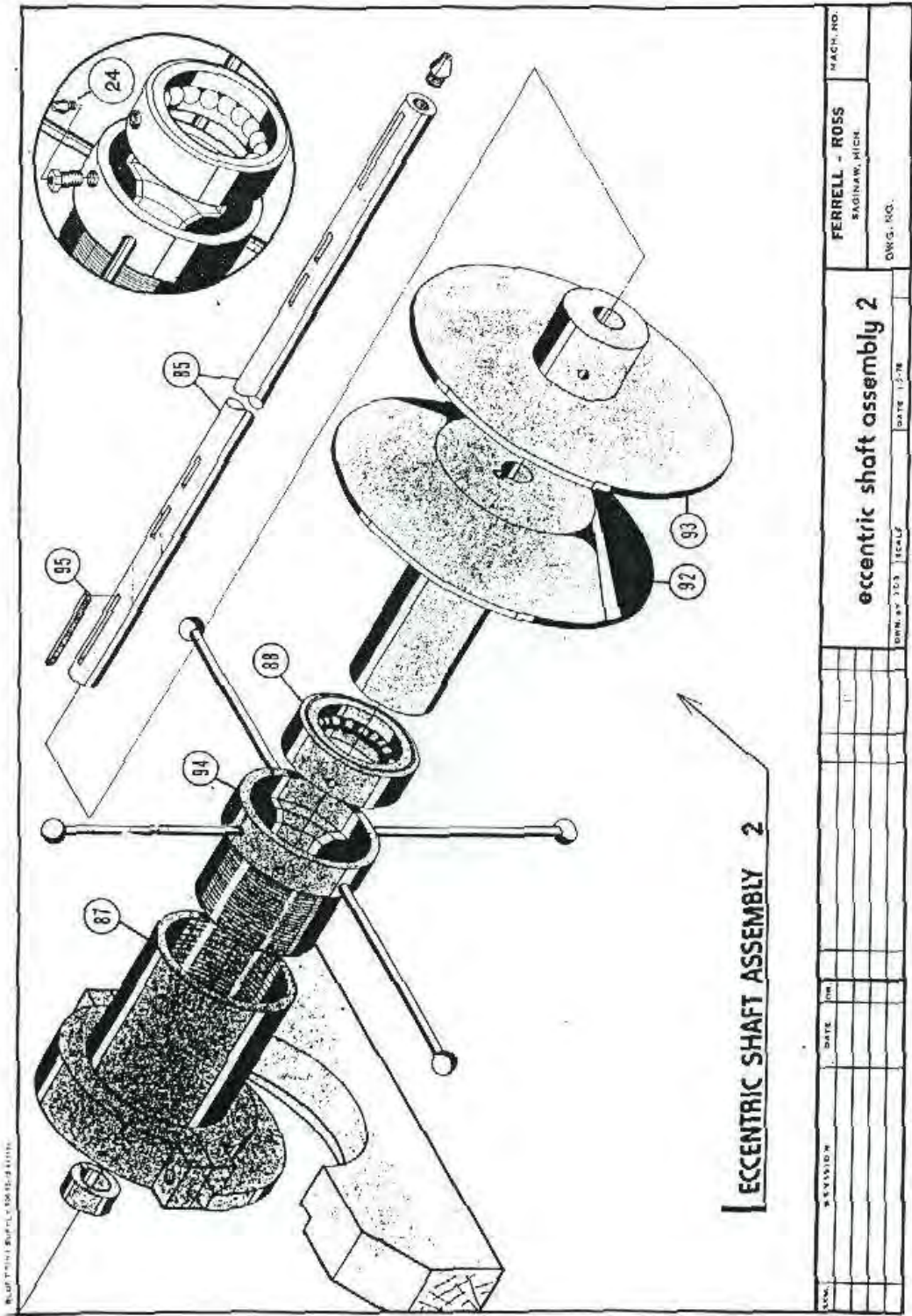

REV.		REVISION		DATE	BY	CHKD.	APP'D.	DATE	BY	CHKD.	APP'D.	DATE	BY	CHKD.	APP'D.
eccentric shaft assembly 2										DWG. NO. 305		TECH. 2		DATE 11-2-78	
FERRELL - ROSS										BAGINAW, MICH		DWG. NO.		MACH. NO.	



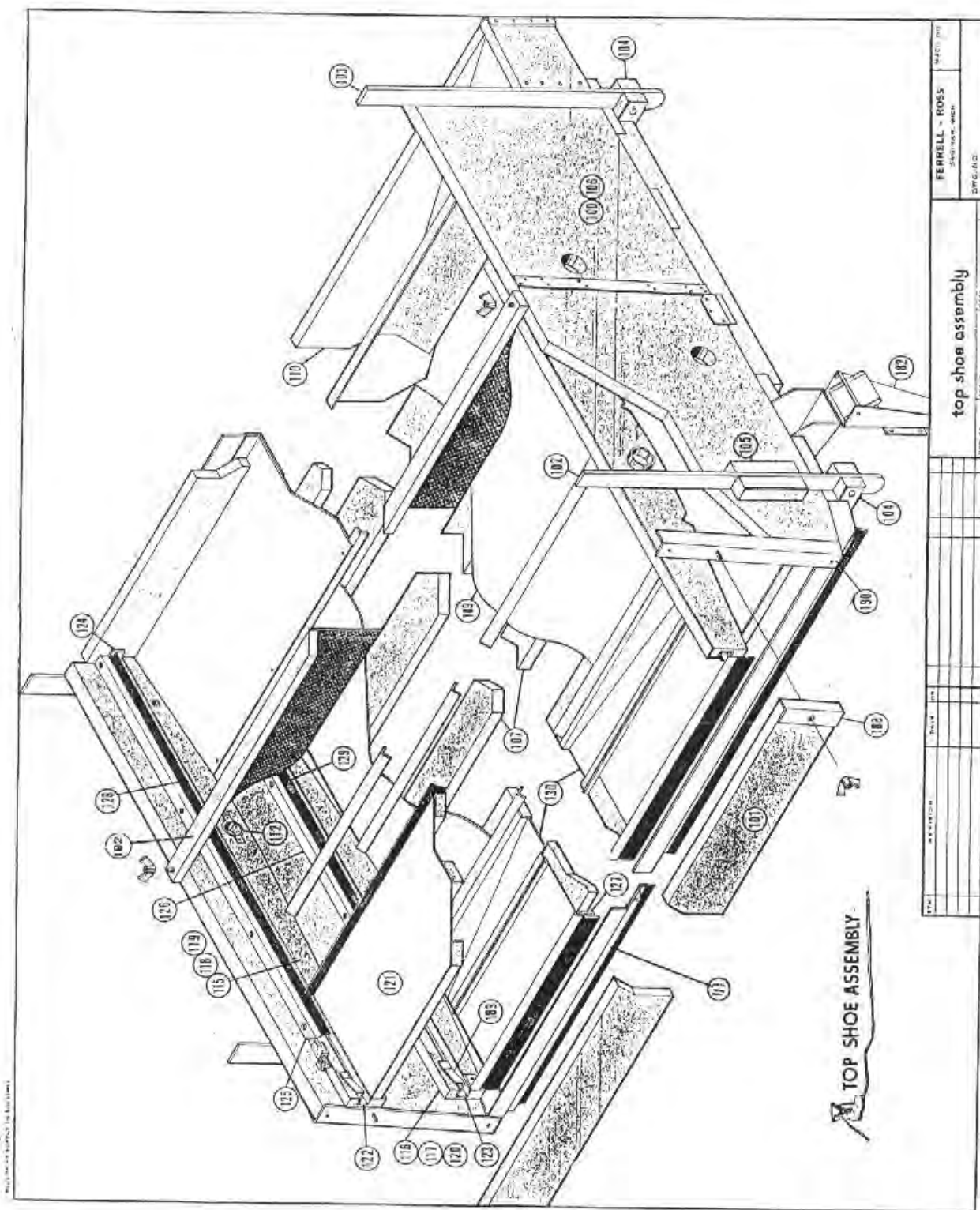



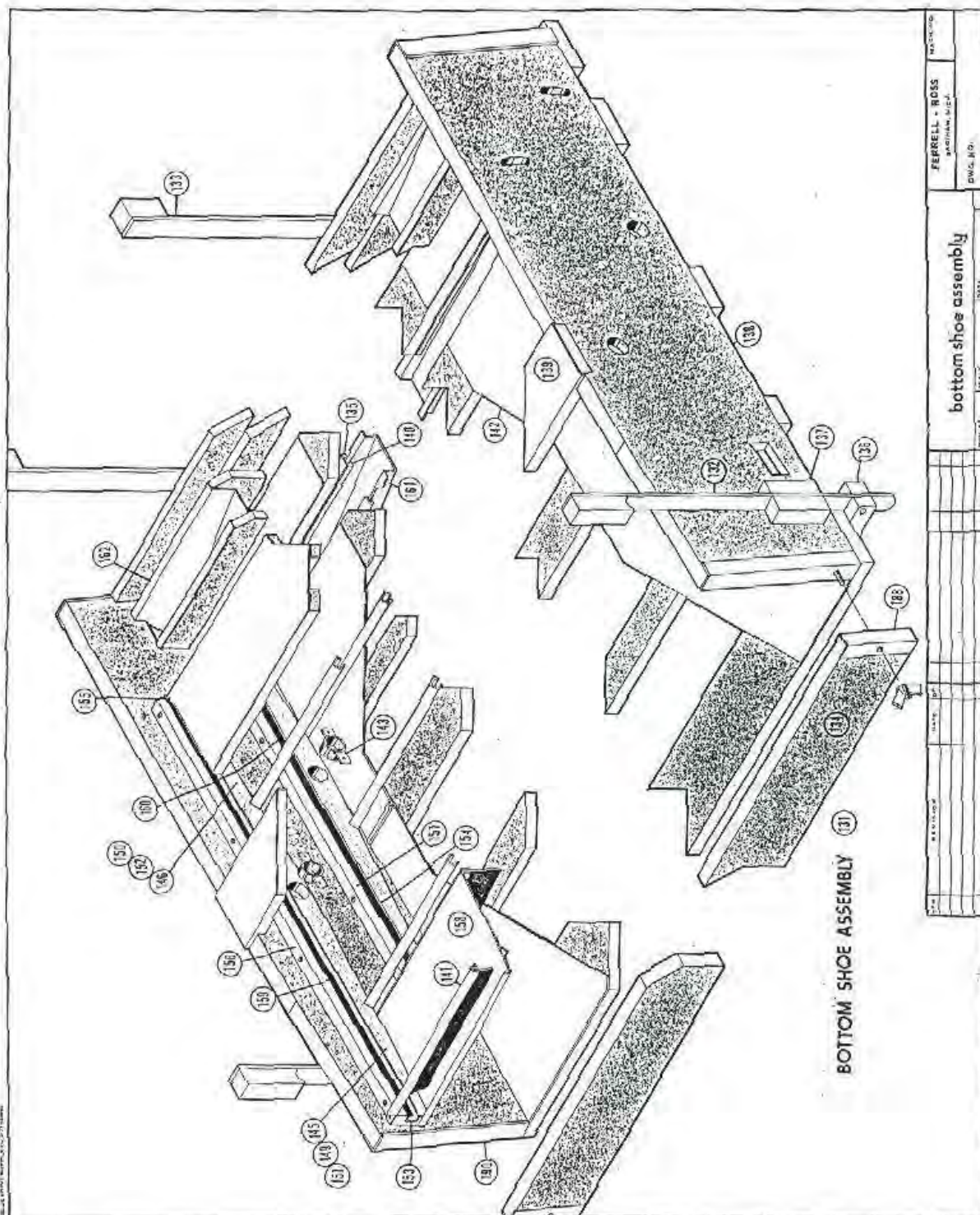

**BOTTOM SHOE ASSEMBLY (31)**

100			
101			
102			
103			
104			
105			
106			
107			
108			
109			
110			
111			
112			
113			
114			
115			
116			
117			
118			
119			
120			
121			
122			
123			
124			
125			
126			
127			
128			
129			
130			
131			
132			
133			
134			
135			
136			
137			
138			
139			
140			
141			
142			
143			
144			
145			
146			
147			
148			
149			
150			
151			
152			
153			
154			
155			
156			
157			
158			
159			
160			
161			
162			
163			
164			
165			
166			
167			
168			
169			
170			
171			
172			
173			
174			
175			
176			
177			
178			
179			
180			
181			
182			
183			
184			
185			
186			
187			
188			
189			
190			

FERRELL - BOSS  
 20010154  
 bottom shoe assembly  
 DWG. B10.  
 1987



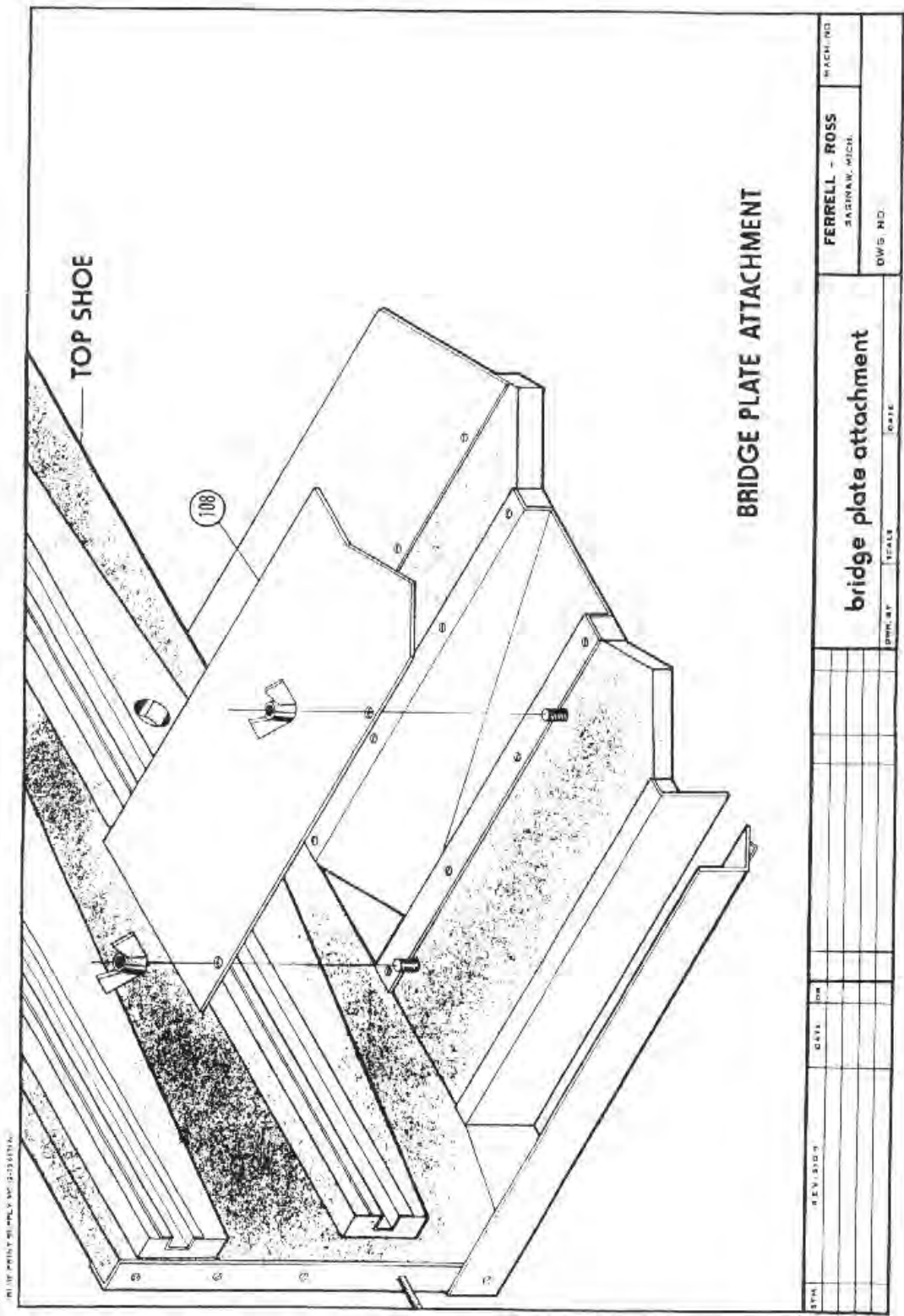

BY THE PRINTING SHOP OF THE STATE ENGINEER

REV.		DATE	BY	SCALE	DATE
bridge plate attachment					
FERRELL - ROSS		DRAWING ENGINEER		DWG. NO.	

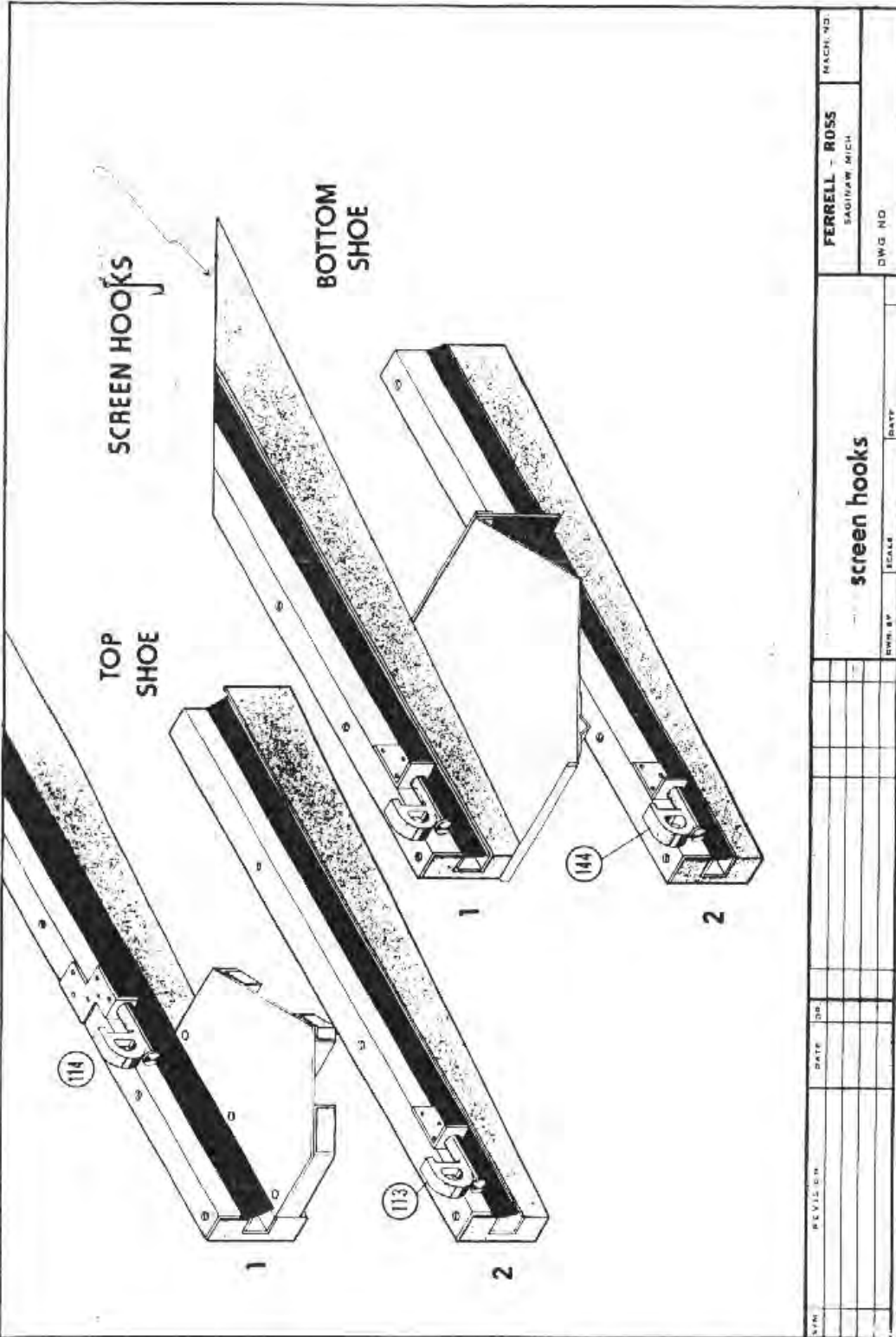

DATE		DATE		DATE		DATE		DATE		DATE	
REV	BY	DATE	CHK	DATE	CHK	DATE	CHK	DATE	CHK	DATE	CHK
screen hooks											
DWG NO						SCALE					
FERRELL - ROSS						MACH NO					
SAGINAW, MICH						DWG NO					

BLUE PRINT SUPPLY COMPANY, INC.

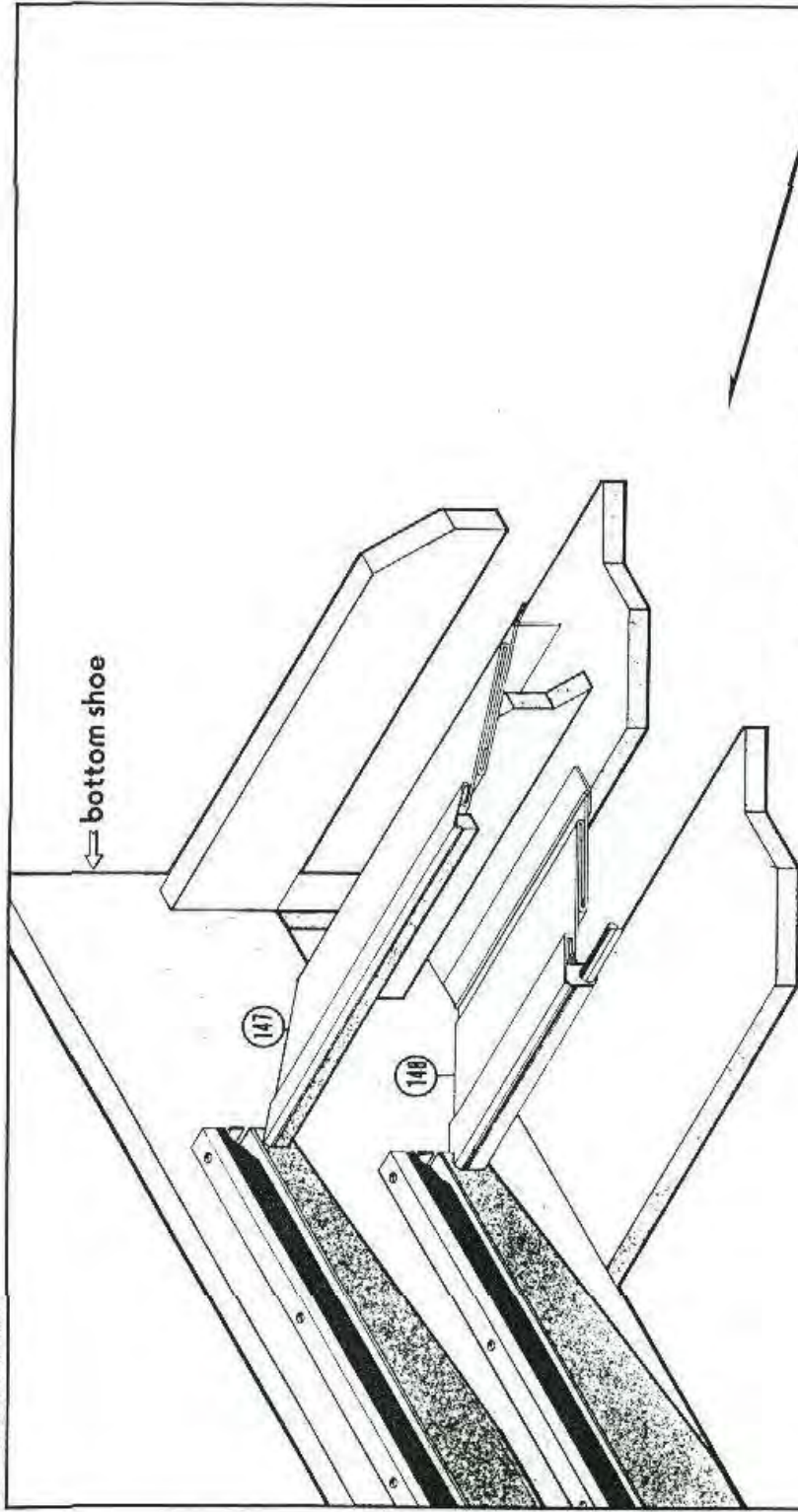

← bottom shoe

### ARRANGEMENT FOR TELESCOPIC APRONS

SYM	REVISION	DATE	BY	SCALE	DATE	FERRELL - ROSS		MECH. NO
						SAGINAW, MICH		
DWG. NO						DWG. NO		

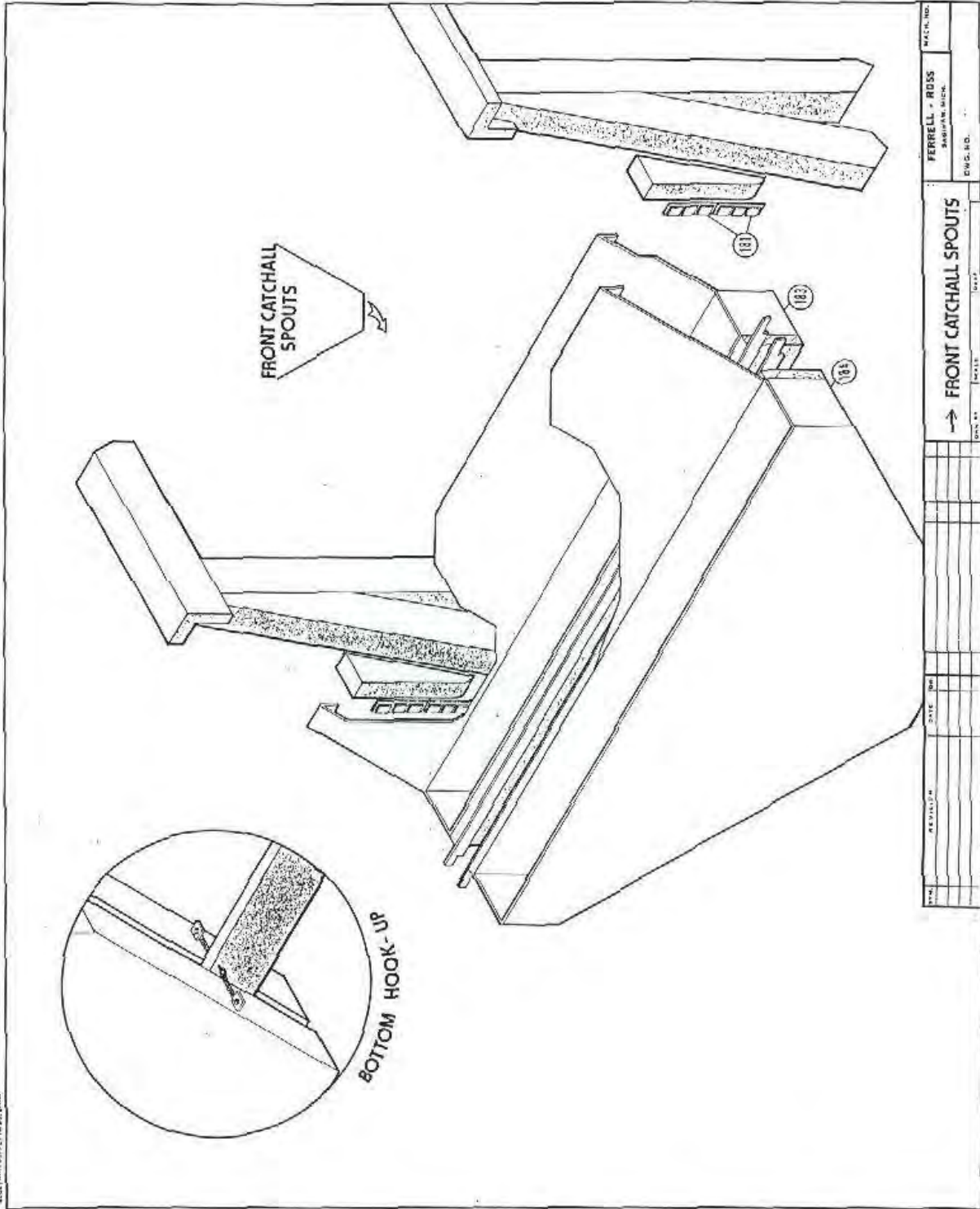

<b>FERRELL - ROSS</b> <small>SHAWAN SICK</small>		<small>DATE</small>	
		<small>ENG. NO.</small>	
<b>FRONT CATCHALL SPOUTS</b>			
<small>NO.</small>	<small>REV.</small>	<small>DATE</small>	<small>BY</small>



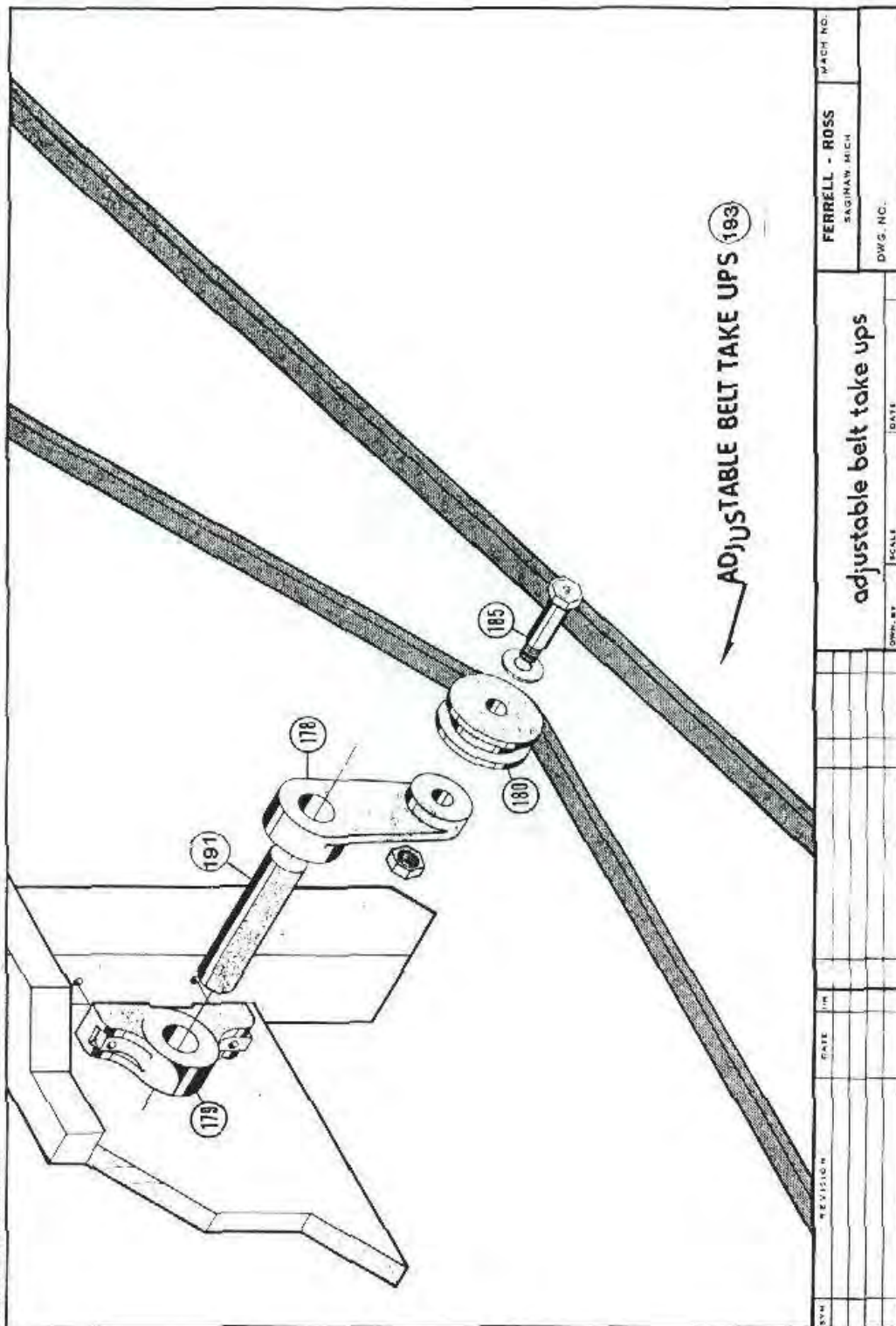

FERRELL - ROSS SASINAW, N.C.		DWS - NC.	
MACH. NO.		DATE	
adjustable belt take ups			
NO.	REVISION	DATE	SCALE

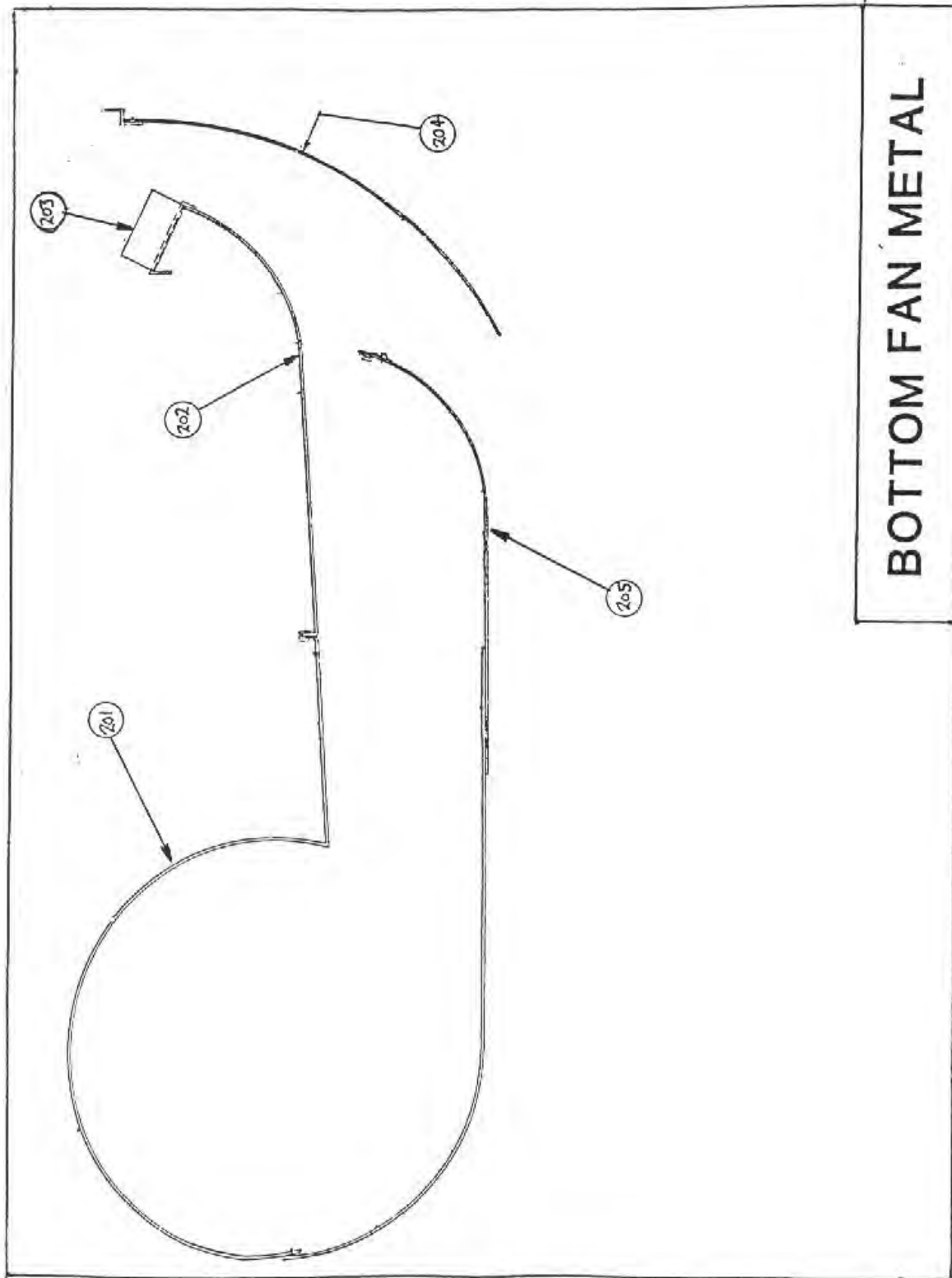

**BOTTOM FAN METAL**

25

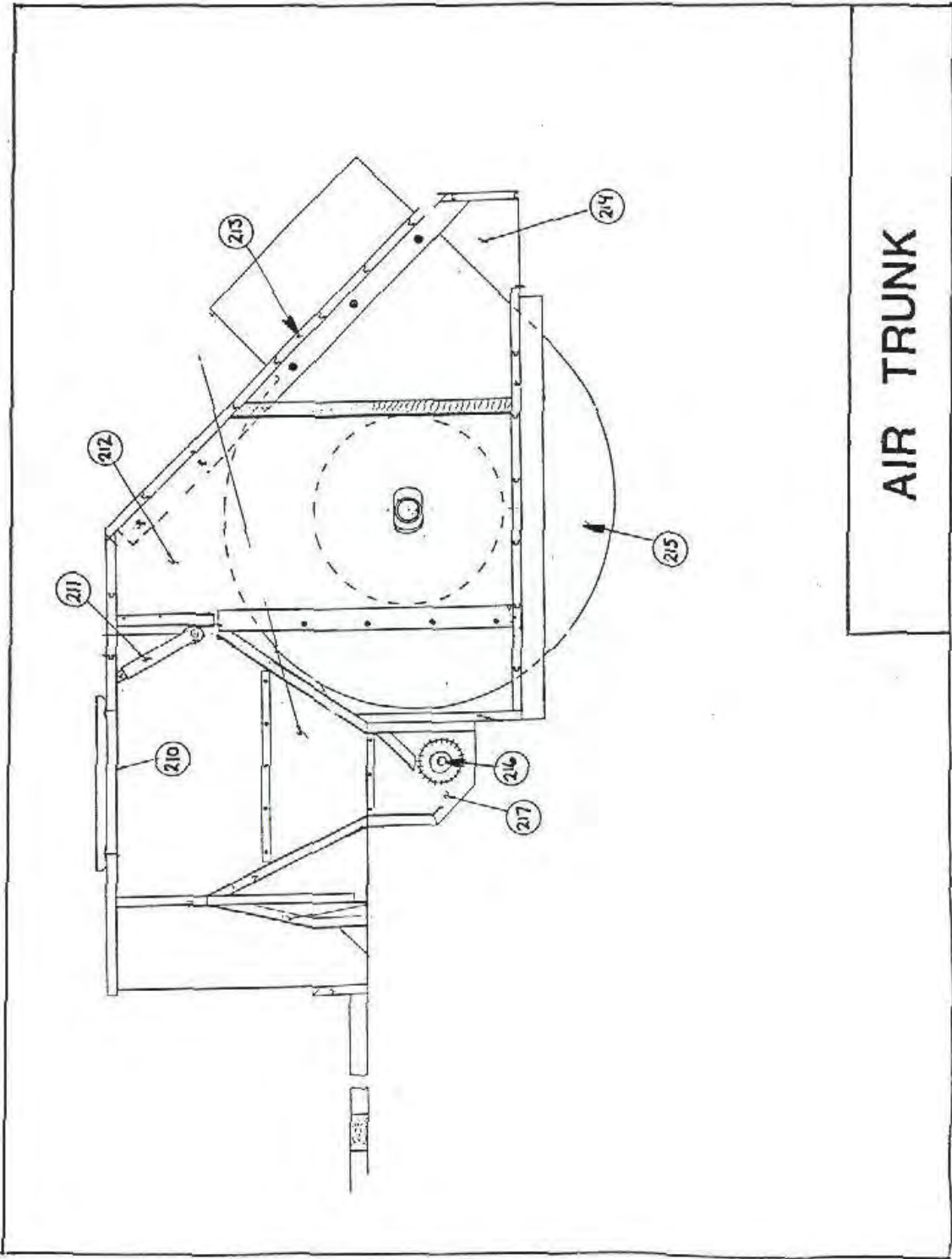

AIR TRUNK

# Rocker Assembly View Ball Trays

