

BOLTS & KEY INCLUDED W/BUSHING SEE SALES ORDER FOR SHEAVE, K915-27301 SHEAVE, 6C18.0 F

6 PLCS MATCHED SET

BOLTS & KEY INCLUDED W/BUSHING SEE SALES ORDER FOR SHEAVE, 1:1 RATIO, K915-27301 SHEAVE, 6C18.0 F

1.05:1 RATIO, K915-27401 SHEAVE, 6C19.0 MTD F (SHOWN)

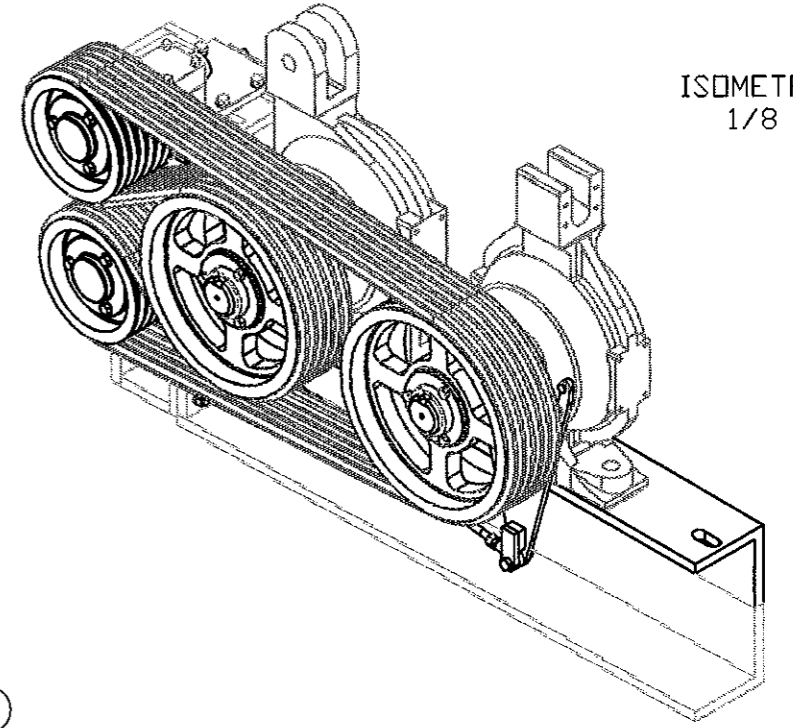

ISOMETRIC VIEW
1/8 SCALE

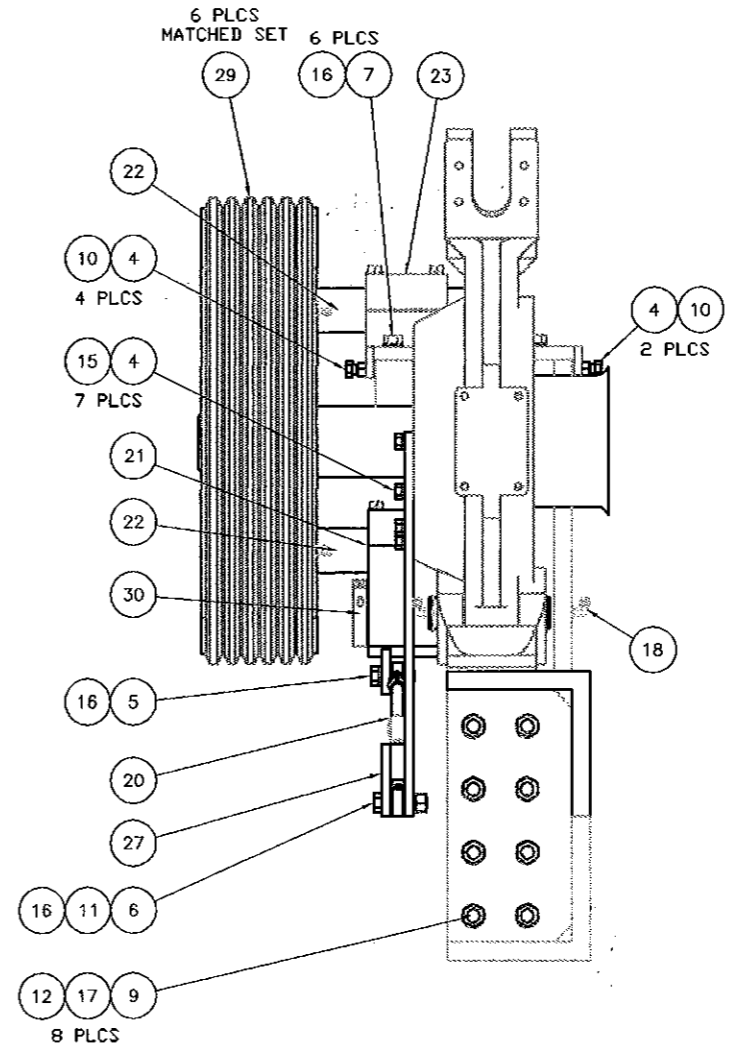
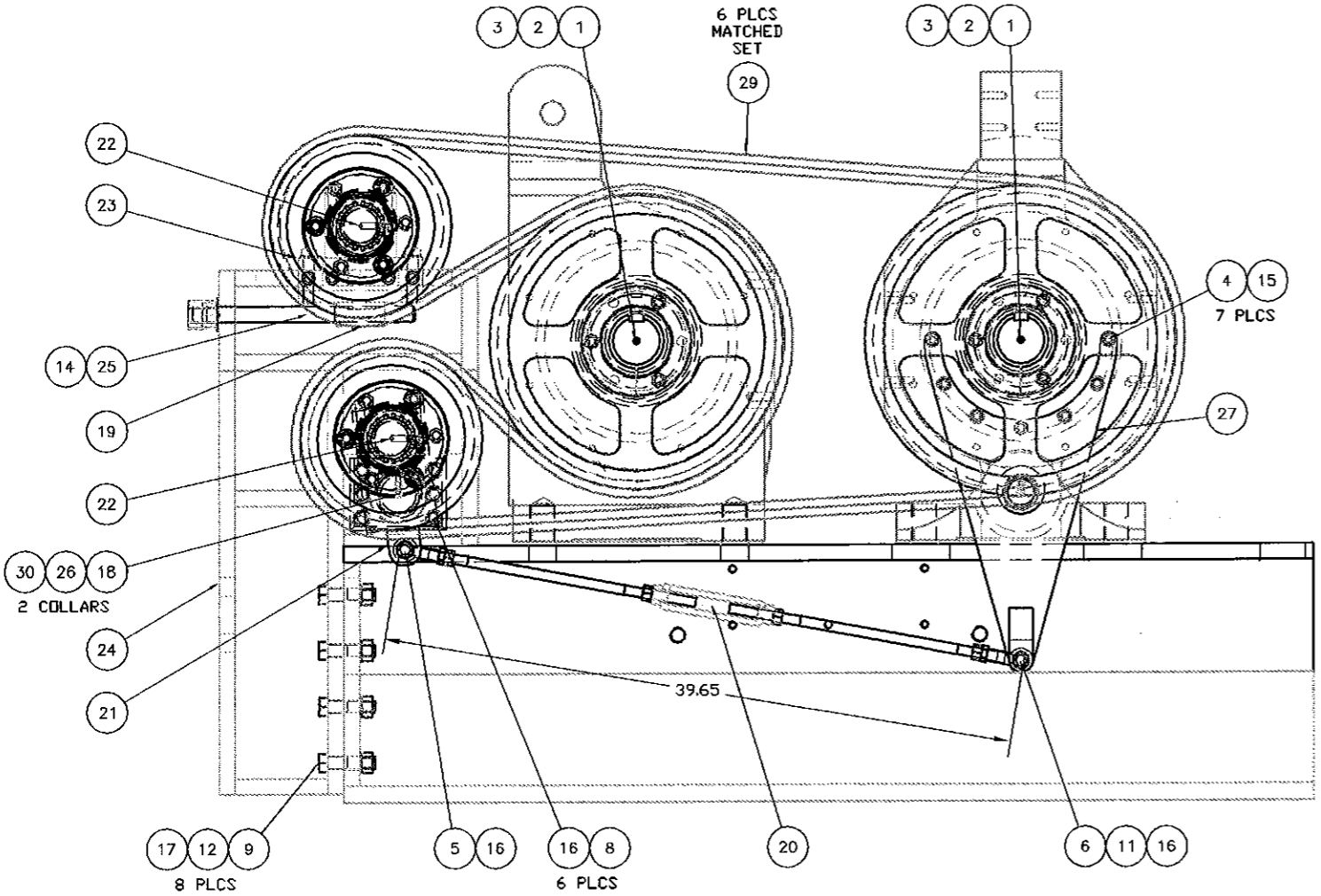

Item	PART NUMBER	Qty	DESCRIPTION
30	K908-11801	2	COLLAR, LOCK 2.50" M TYPE 1-PC M40L
29	K903-06301	6	BELT, CC-210
28	K200-02172	1	ADJ BOLT WLDMT, 1-8 X 8.38"
27	K200-02121	1	ARM, TENSION, DIFF IDLER 24"
26	K200-02120	1	SHAFT WLDMT, IDLER SWING ARM 24"
25	K200-02117	1	ADJ BOLT WLDMT, 1-8 X 12.38"
24	K200-02115	1	SPRRT WLDMT, TOP IDLER BRKT, ARR 5&8, 24"
23	K100-02114	1	BRKT WLDMT, TOP IDLER, 24"
22	K100-01935	2	SHEAVE ASSY, DIFF IDLER 24"
21	K100-00465	1	SWING ARM ASSY, DIFF IDLER 24"
20	K100-00421	1	TURNBUCKLE ASSY, DIFF IDLER 24"
19	K100-00202	1	ADJ PLT WLDMT, DIFF IDLER 24"
18	70012050	1	CPLG, ELBOW 90° 1/8-27M NPT X 1/4" OD TBG
17	66446400	8	WASHER, LOCK 3/4" PLT
16	66445800	14	WASHER, LOCK 5/8"
15	66445200	7	WASHER, LOCK 1/2"
14	66407400	2	WSHR, FLAT 1" PLT
13	66087400	1	NUT, HEX 1-8 PLT
12	66086400	8	NUT, HEX 3/4-10 PLT
11	66085800	1	NUT, HEX 5/8-11 PLT
10	66085200	6	NUT, HEX 1/2-13
9	62586442	8	HHCS, 3/4-10 X 3.00"
8	62585846	6	HHCS, 5/8-11X 3.50"
7	62585842	6	HHCS, 5/8-11X 3.00"
6	62585837	1	HHCS, 5/8-11X 2.50"
5	62585833	1	HHCS, 5/8-11X 2.00"
4	62585226	13	HHCS, 1/2-13 X 1.25"
3	44011549	6	HHCS, 9/16-12 X 3.63"
2	44011549	2	KEY, RECT 5/8 X 7/8 X 4.00"
1	44011549	2	BSHG, QD F 3.438"

NOTES:
1. DO NOT SCALE FROM DRAWING.
2. ONE PIECE REQUIRED PER K000-02068/-02180/-02456: ROLLER MILL ASSY, 24 X 48/36/56.
3. DRIVE & DRIVEN SHEAVES (K915-27301 & K915-27401) ARE LINE ITEMS ON THE SALES ORDER.

This drawing is the property of the A.T. Ferrell Company, Inc and must be returned immediately upon request. No part of this drawing may be reproduced, stored in a retrieval system or transmitted in any form or by any means, without prior written consent of the A.T. Ferrell Company, Inc

Ferrell-Ross
MATERIALS PROCESSING & RECOVERY

A DIVISION OF A.T. FERRELL COMPANY
BLUFFTON, SOUTH CAROLINA, U.S.A.

DECIMAL: ± .005
FRACTIONAL: ± 1/32
ANGULAR: ± 1/2°

SCALE: 3/16
DRAWN BY: DJ
APPROVED BY: X.X.X.

DRAWING TITLE: DIFF IDLER ASSY, ARR 5 & 8 (RH STD) 24"

DATE: 3/9/02
SIZE: D
DRAWING NO.: K100-00466
SHEET: 1 of 2