

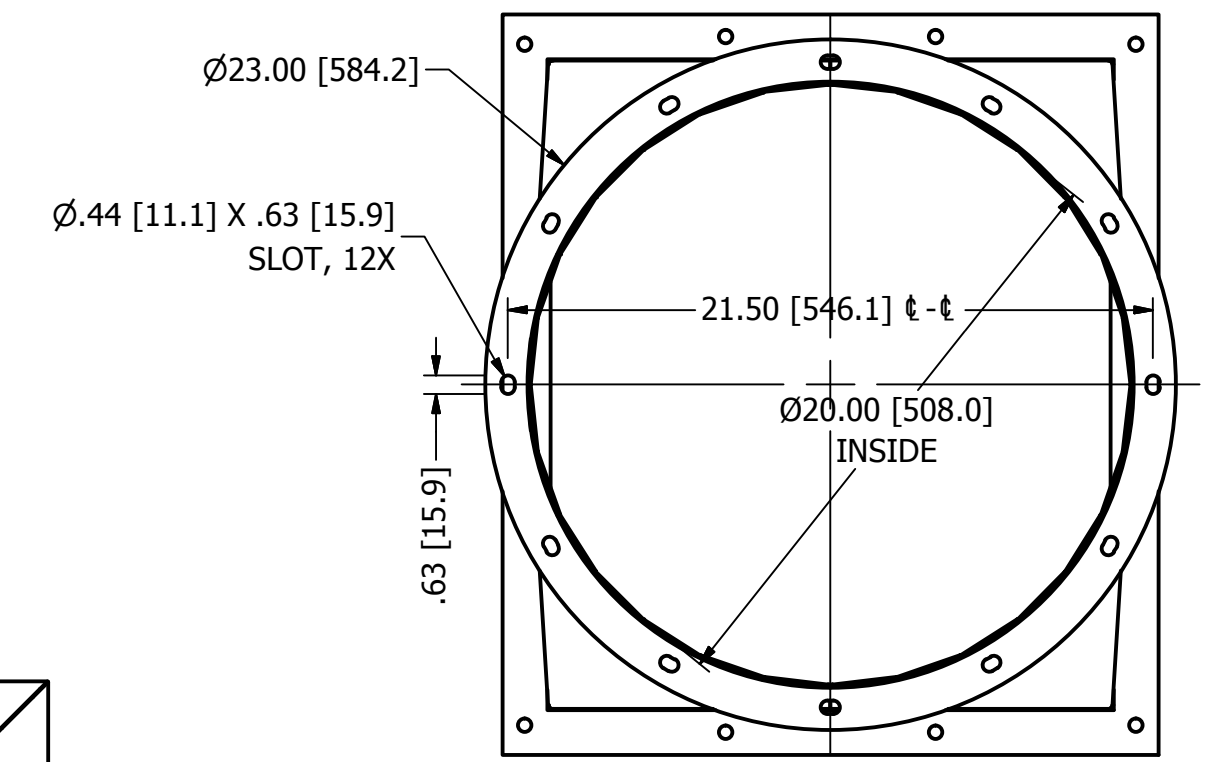

REVISION HISTORY				
REV	ECN	DESCRIPTION	DATE	APPROVED
A	F110066	RELEASE	4/15/2011	dmjohnson
B	F140143	F66682003 WAS F66682001	9/10/2014	dmjohnson

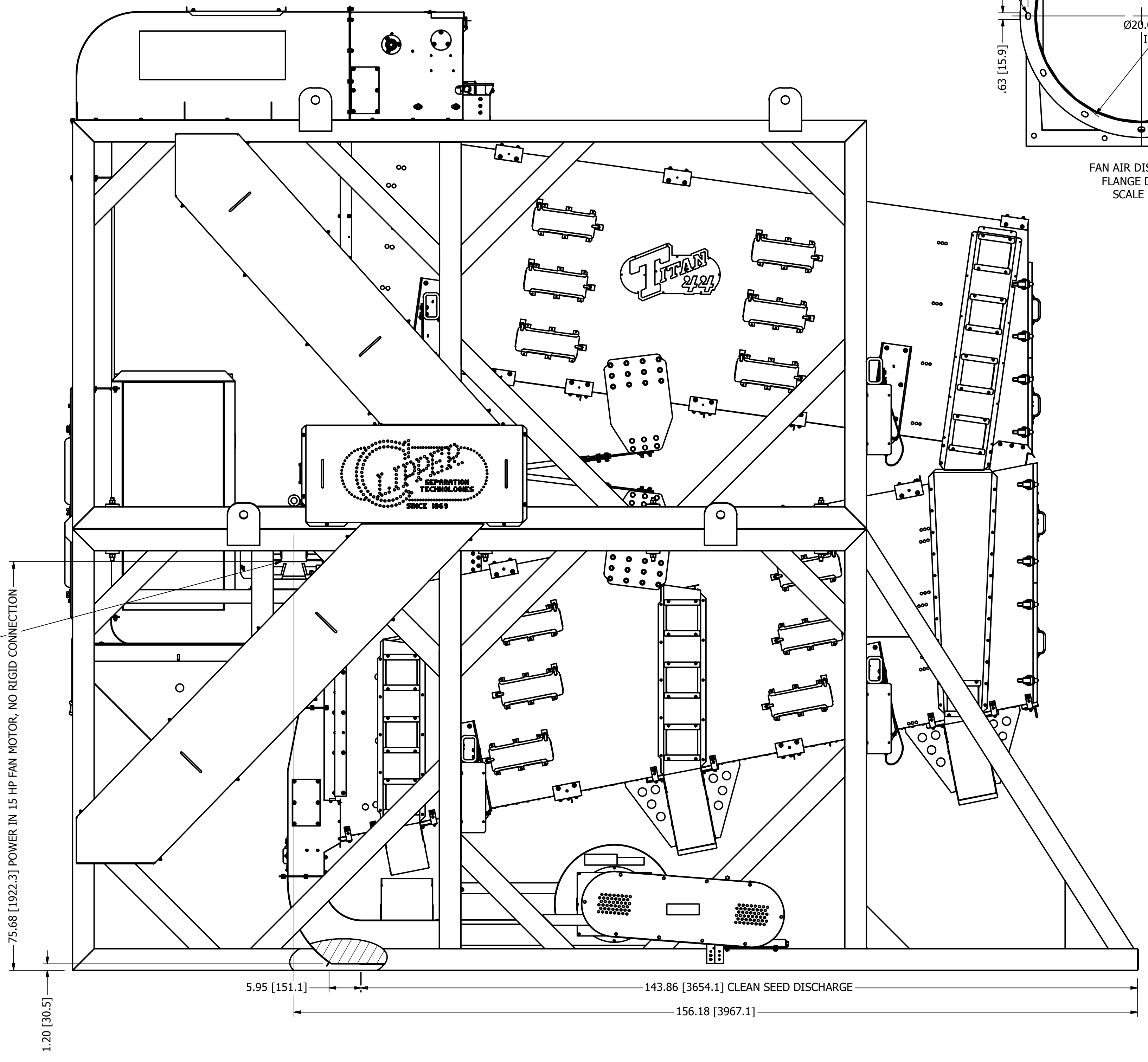
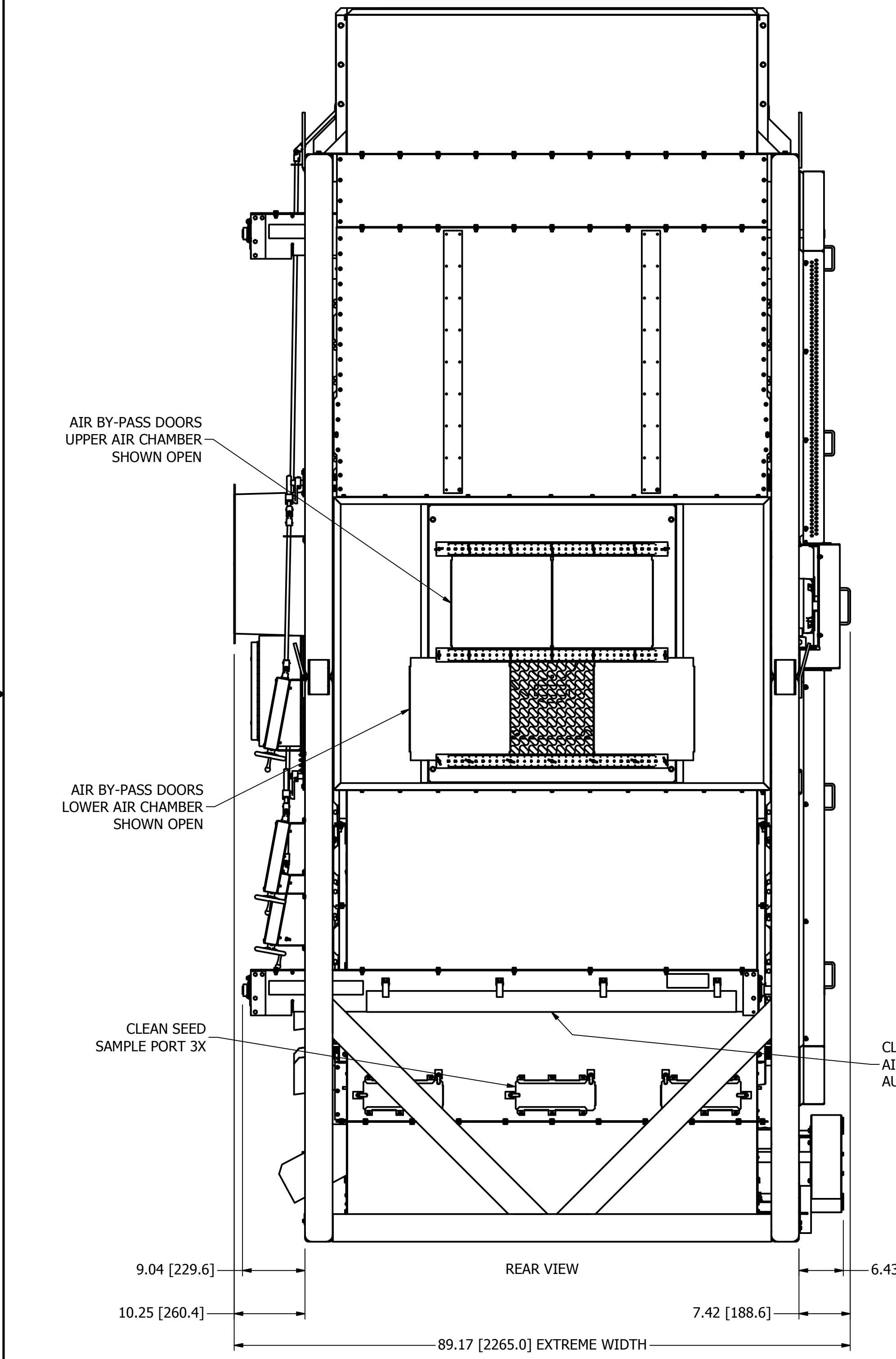

NOTES:

- DO NOT SCALE FROM DRAWING.
- ALTERNATIVE UNITS [X.X] IN MILLIMETERS.
- .500-.875" [12.70-22.23mm] TOTAL THROW, BOTH SHOES.
- CONTACT CLIPPER SALES FOR CFM [CMM] REQUIREMENTS, GIVEN SPECIFIC APPLICATION.
- MACHINE SHIPPED IN TWO SECTIONS. UPPER SECTION SHIPPING WEIGHT: 5500 lb [2495 kg]. LOWER SECTION SHIPPING WEIGHT: 7750 lb [3515 kg].
- EIGHT, 3/4-8 GRADE 5 BOLTS RECOMMENDED TO LAG FRAME THRU FLOOR JOISTS.
- RECOMMENDED MAINTENANCE CLEARANCE FROM FRAME: 48.00" [1219] AT FRONT & SIDES, 12.00" [305] AT REAR.
- FRAME ASTM A500 GRADE B (UNS K03000) 4.00 X 4.00 X 0.25 & 0.50" PAINTED FINISH.
- SEE PRINT 1 OF 3 FOR FRONT & RIGHT SIDE VIEWS. SEE PRINT 3 OF 3 FOR TOP (INLET) & BOTTOM (OUTLET & MOUNTING) VIEWS.

This drawing is the property of the A.T. Ferrell Company, Inc and must be returned immediately upon request. No part of this drawing may be reproduced, stored in a retrieval system or transmitted in any form or by any means, without prior written consent of the A.T. Ferrell Company, Inc.	CAD NO MANUAL CHANGES EXCEPT AS NOTED	 DIVISION OF A. T. FERRELL COMPANY BLUFFTON, INDIANA - USA
	TOLERANCES DECIMAL: .005 FRACTIONAL: 1/32 ANGULAR: 1/2	