

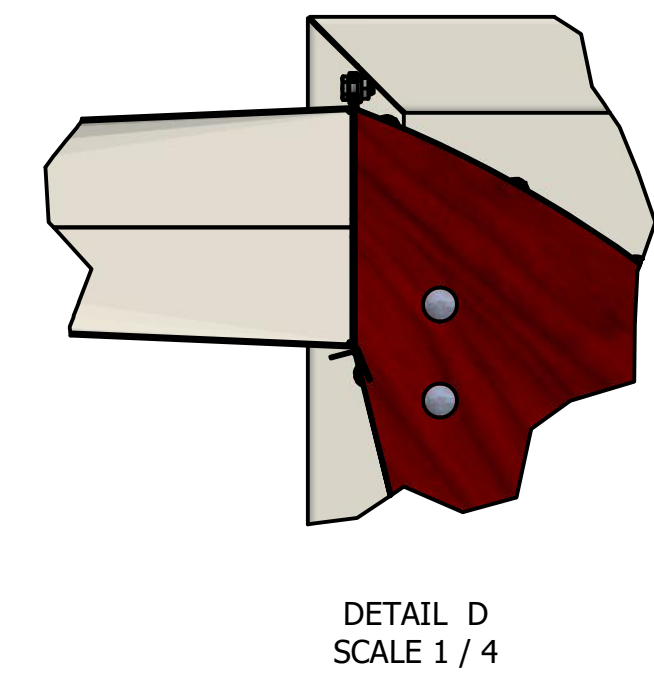

REVISION HISTORY				
REV	ECN	DESCRIPTION	DATE	APPROVED
A	F050014	RELEASE PRINT	3/9/2005	dmjohnson
B	F110172	REDRAWN INVENTOR, ADD SHEETS 2-4	10/27/2011	dmjohnson
C	F110241	ADD MOTOR INFO NOTES & MOTOR W/O SWITCH CUTAWAY VIEWS	11/9/2011	dmjohnson
D	F120088	ADD SHEET 5: VS BTM FAN	10/24/2012	dmjohnson
E	F130069	1 HP DRIVE MOTOR WAS 3/4 HP	5/7/2013	dmjohnson
F	F180059	ADDED SHEETS 6, 7, & 8	7/13/2018	samelching

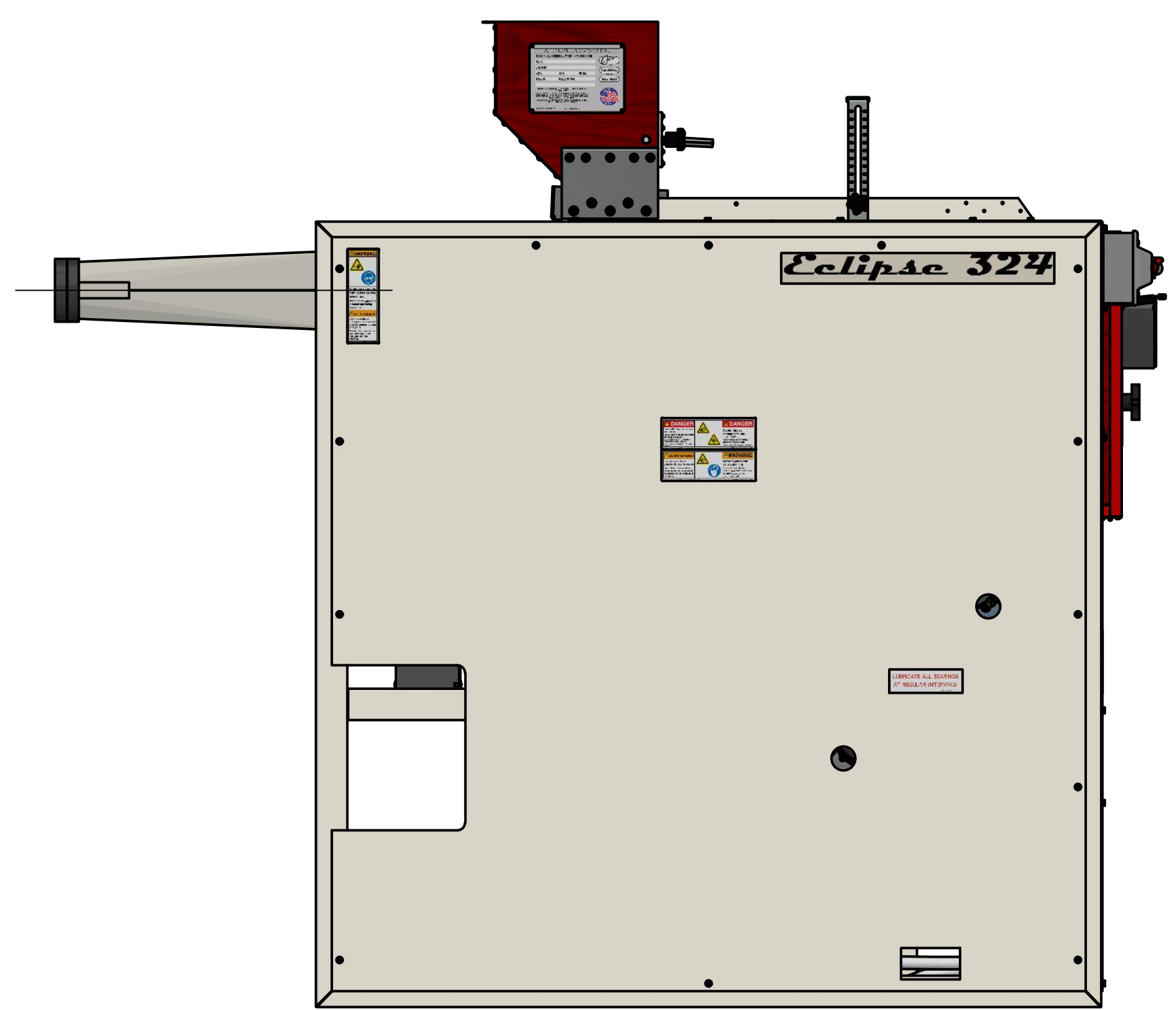
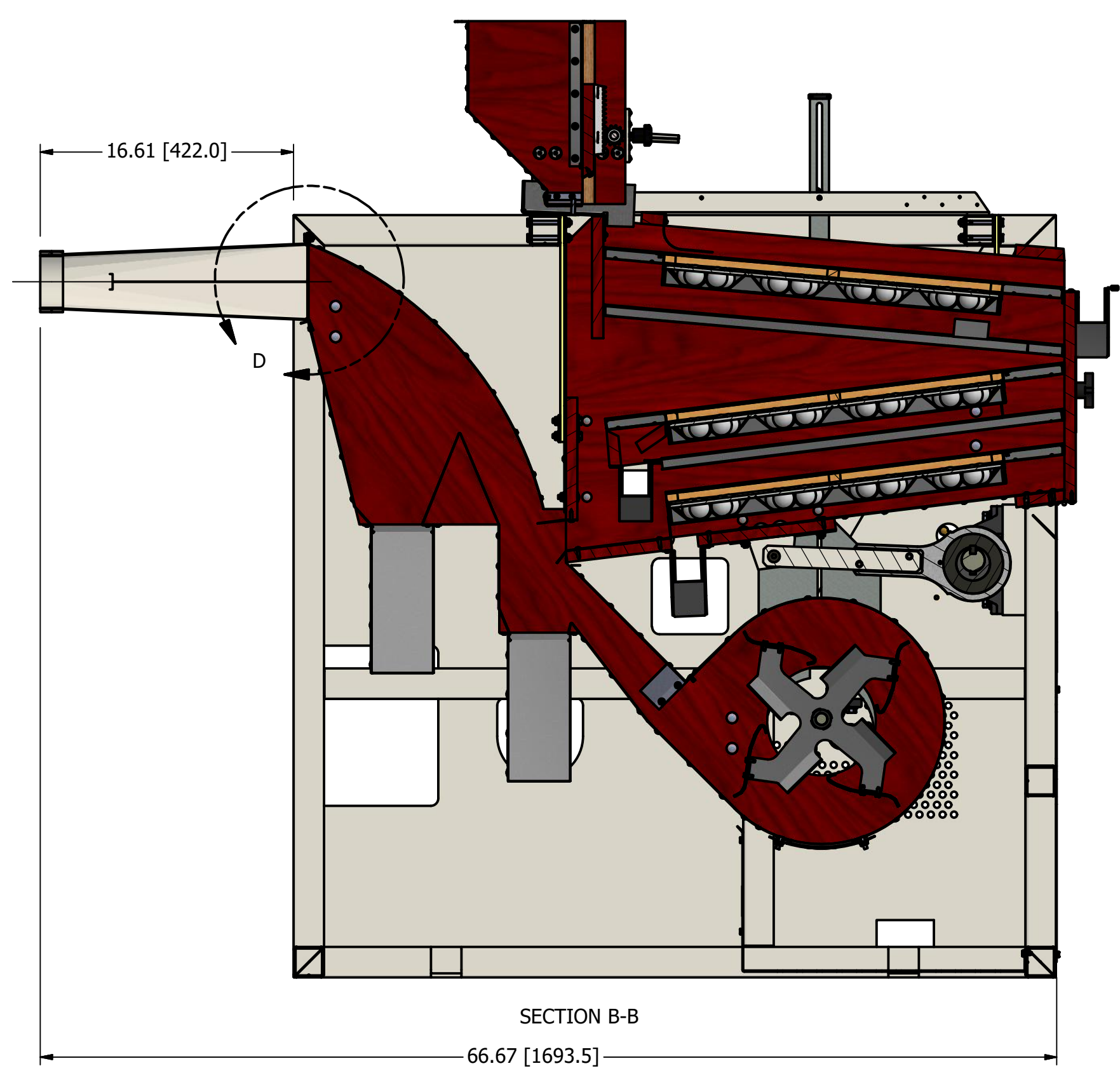
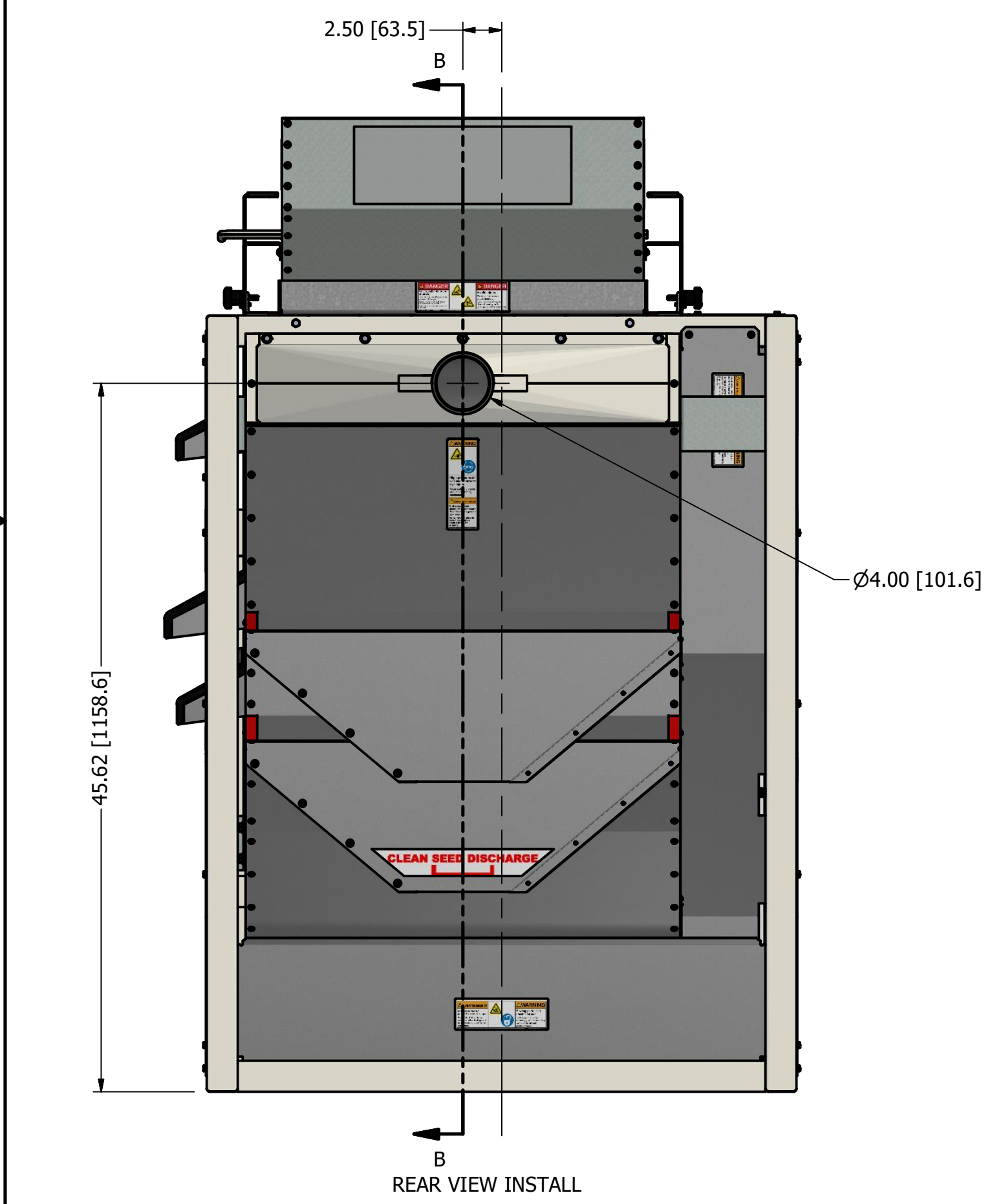

- NOTES:
- DO NOT SCALE FROM DRAWING.
  - ALTERNATIVE UNITS [X.X] IN MILLIMETERS.
  - MACHINE WEIGHT AS SHOWN: 770 LBS / 349 KG. SHIPPING WEIGHT AS SHOWN: 840 LBS / 381 KG.
  - 0.50" [12.7] TOTAL THROW, SHOE.
  - VARIABLE FAN AIR DISCHARGE: 0 CFM / 0 CMM TO 1600 CFM / 45 CMM MAXIMUM.
  - FOUR 1/2-13 GRADE 5 BOLTS RECOMMENDED TO LAG FRAME THRU FLOOR JOISTS.
  - RECOMMENDED MAINTENANCE CLEARANCE FROM FRAME: 36.00" [915] AT FRONT & SIDES, 12.00" [305] AT REAR.
  - FUSED DISCONNECT REQUIRED PRIOR TO MACHINE MOUNTED SWITCH BOX.
  - VARIABLE SPEED AC BOTTOM FAN MOTOR: 100-120 VAC 1Ø 50/60 HZ POWER IN, 1 HP 3Ø 60 HZ 230/460V INVERTER DUTY TENV, FULL LOAD AMPS 3.0.
  - VARIABLE SPEED AC BOTTOM FAN MOTOR: 200-240 VAC 1Ø 50/60 HZ POWER IN, 1 HP 3Ø 60 HZ 230/460V INVERTER DUTY TENV, FULL LOAD AMPS 3.0.
  - VARIABLE SPEED AC BOTTOM FAN MOTOR: 380-440 VAC 3Ø 50/60 HZ POWER IN, 1 HP 3Ø 60 HZ SPECIAL, CALL FOR AVAILABILITY.
  - VARIABLE SPEED AC BOTTOM FAN MOTOR: 440-480 VAC 1Ø 50/60 HZ POWER IN, 1 HP 3Ø 60 HZ 230/460V INVERTER DUTY TENV, FULL LOAD AMPS 1.5.
  - VARIABLE SPEED AC BOTTOM FAN MOTOR: 500-600 VAC 3Ø 50/60 HZ POWER IN, 1 HP 3Ø 60 HZ SPECIAL, CALL FOR AVAILABILITY.
  - VARIABLE SPEED DC BOTTOM FAN MOTOR: 100-120 VAC 1Ø 50/60 HZ POWER IN, 1 HP 90VDC TEFC, FULL LOAD AMPS 10.0 ADC.
  - VARIABLE SPEED DC BOTTOM FAN MOTOR: 200-240 VAC 1Ø 50/60 HZ POWER IN, 1 HP 180VDC TEFC, FULL LOAD AMPS 5.0 ADC.
  - FRAME CONSTRUCTION: A500 GR. B STRUCTURAL CFS, PAINTED FINISH.

**4 INCH FAN TRANSITION**

		DIVISION OF A.T.FERRELL COMPANY 1440 S ADAMS ST BLUFFTON, INDIANA 46714 - USA PH: 260-824-3400 FAX: 260-824-5463		This drawing is the property of the A. T. Ferrell Company, Inc. and must be returned immediately upon request. No part of this drawing may be reproduced, stored in a retrieval system or transmitted in any form or by any means, without prior written consent of the A. T. Ferrell Company, Inc.	
TOLERANCES EXCEPT AS NOTED DECIMAL: ± .030 FRACTIONAL: ± 1/32 XX ± .005 XXX ± .001		FINISH: TOUCH-UP PAINT		DRAWN BY: dmjohnson DRAWN DATE: 10/14/2011 APPROVED BY: DMJ	
<b>CAD NO MANUAL CHANGES</b>		SCALE: 1:10	SHEET: 7 OF 8	SIZE: D	PART NUMBER: <b>F6000000-I</b>
					REV: <b>F</b>