

REVISION HISTORY				
REV	ECN	DESCRIPTION	DATE	APPROVED
A	120054	RELEASE	9/26/2012	jmossm

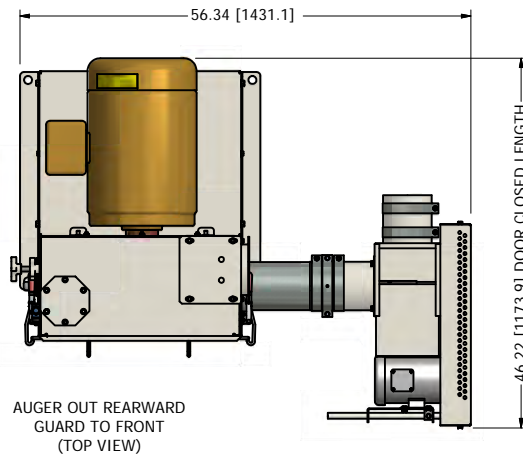

2.40 [61.0] FLOOR TO BOX CLEARANCE

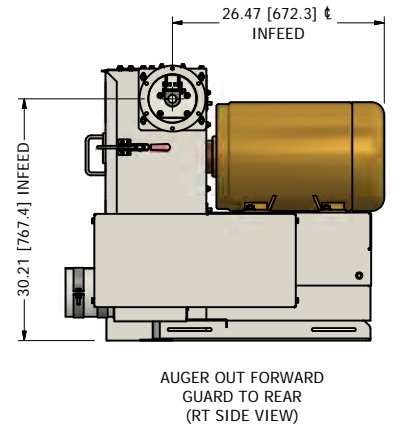
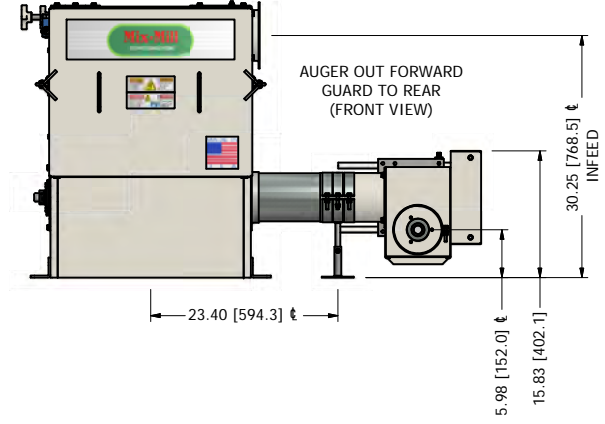
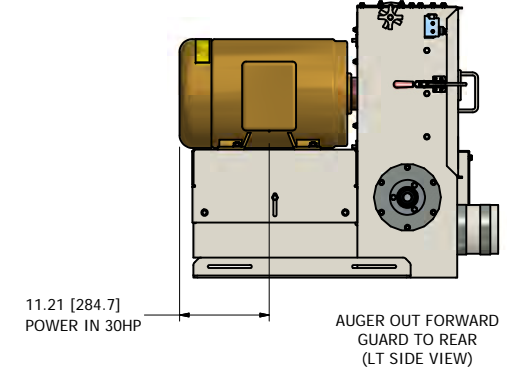
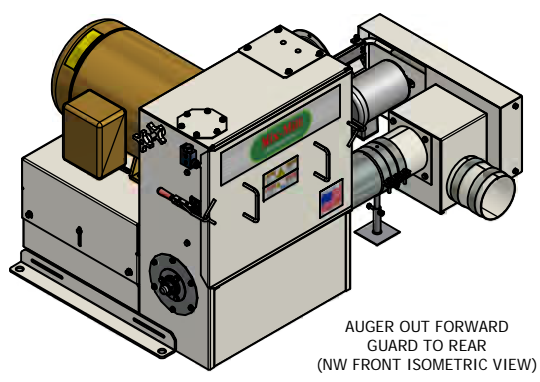
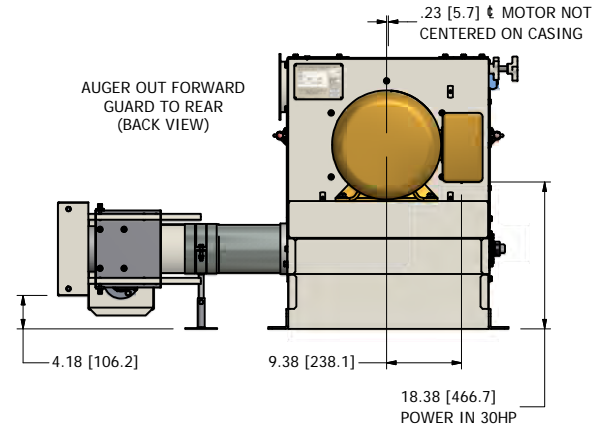
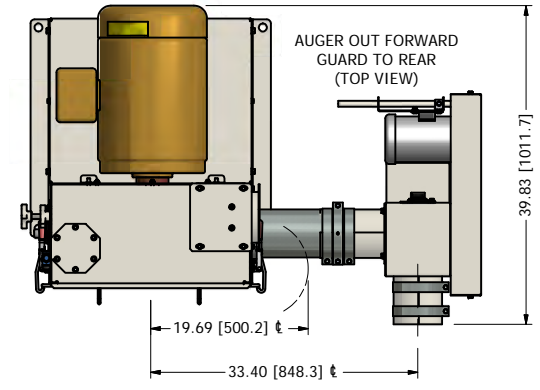
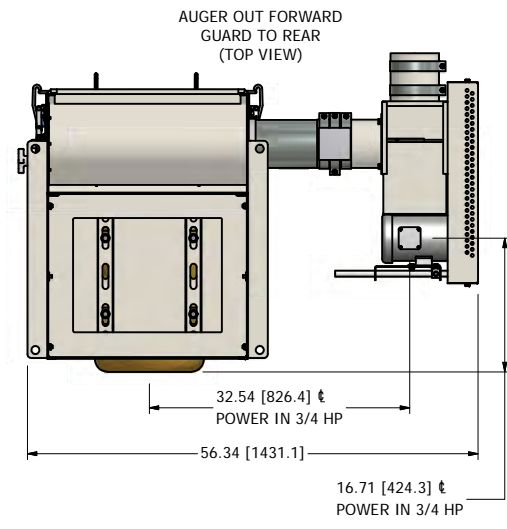
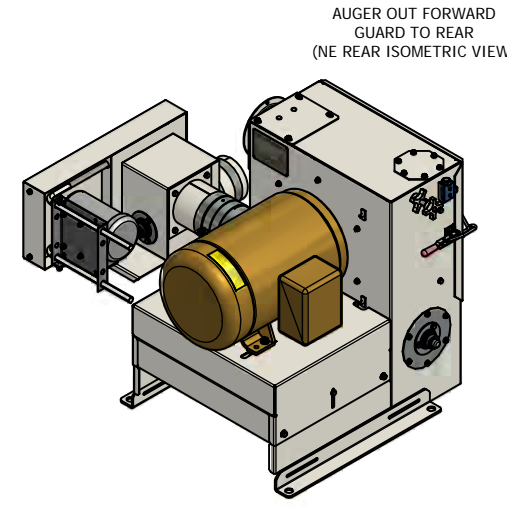
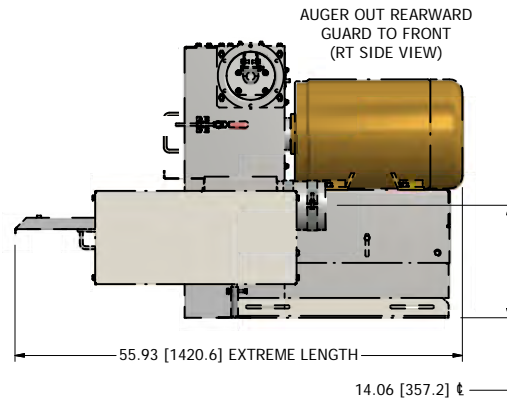
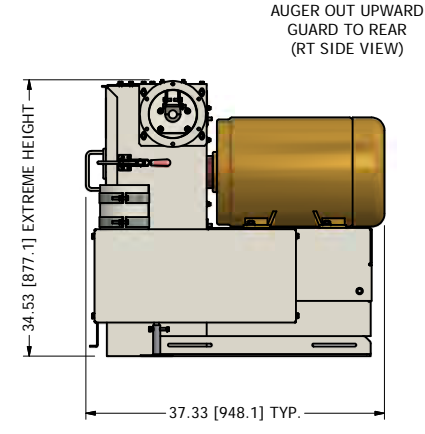
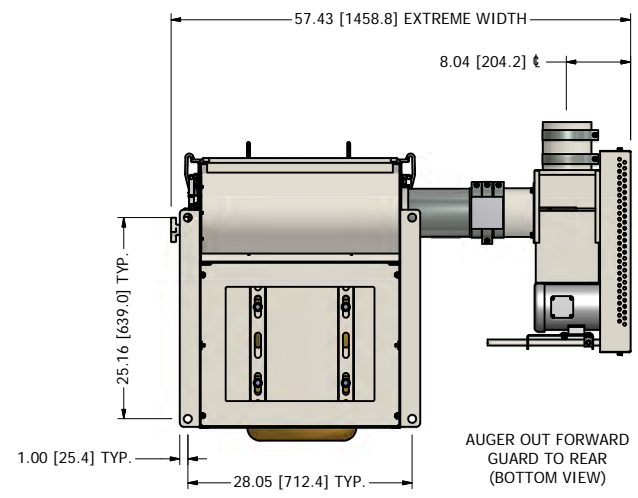
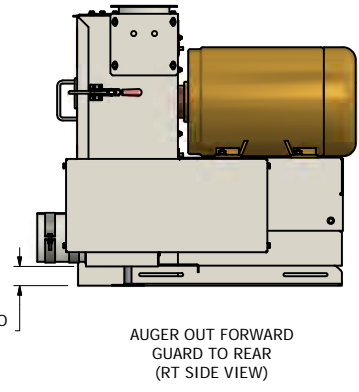

NOTES:
 1. DO NOT SCALE FROM DRAWING.
 2. ALT DIMENSIONS [X.X] IN MILLIMETERS.
 3. RECOMMENDED MAINTENANCE CLEARANCE: FRONT: 36.00 [914.4], SIDE & REAR: 24.00 [609.6].
 4. WEIGHT AS SHOWN WITH 30 HP DRIVE MOTOR: 657 LBS [298 KG].

This drawing is the property of the A.T. Ferrell Company, Inc and must be returned immediately upon request. No part of this drawing may be reproduced, stored in a retrieval system or transmitted in any form or by any means, without prior written consent of the A.T. Ferrell Company, Inc	CAD NO MANUAL CHANGES TOLERANCES EXCEPT AS NOTED			DIVISION OF A. T. FERRELL COMPANY BLUFFTON, INDIANA - USA	
	DECIMAL: .005 XX ± .030 FRACTIONAL: 1/32 ANGULAR: ± 1/2°			FINISH: SCALE: 1:12 DRAWN BY: jmossm APPROVED BY: DMJ	
	TITLE: MILL ASSY, SIDE DISCHARGE, SENTRY 1030		DATE: 7/12/2012	SIZE: D PART NUMBER: 92007110-1	SHEET: 1 of 2
	SHEET: 1 of 2				

REV	ECN	DESCRIPTION	DATE	APPROVED
A	120054	RELEASE	9/26/2012	jmosse

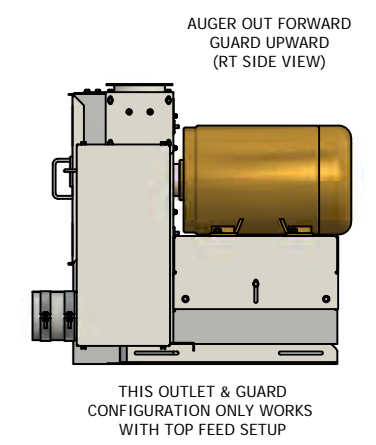
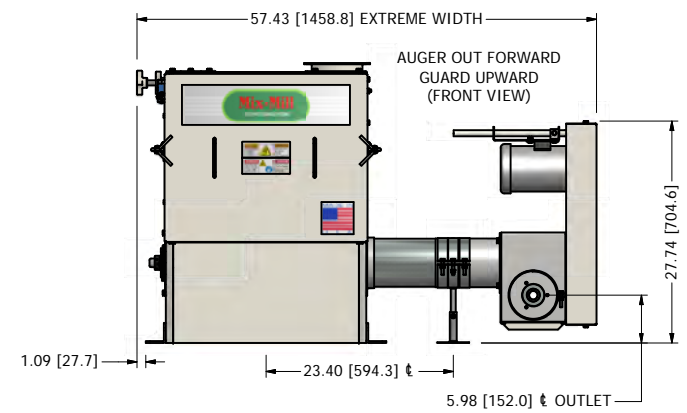
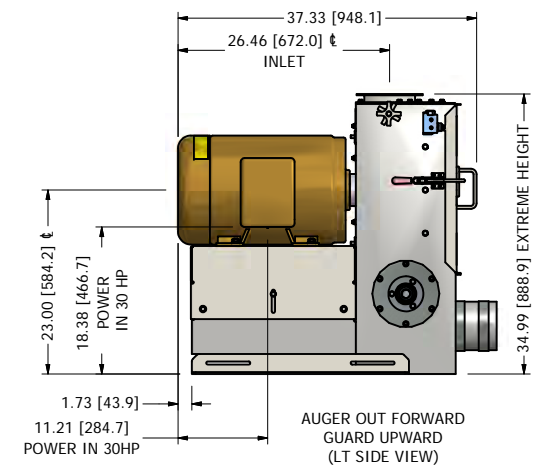
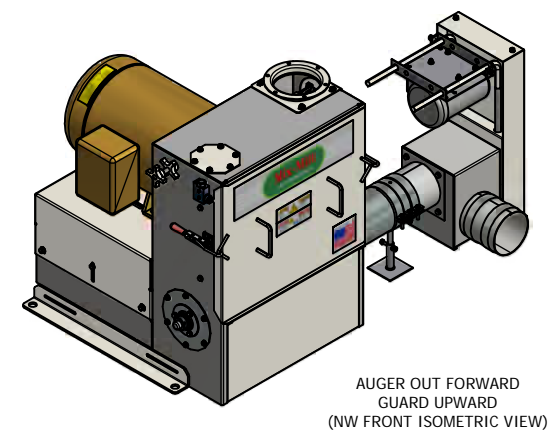
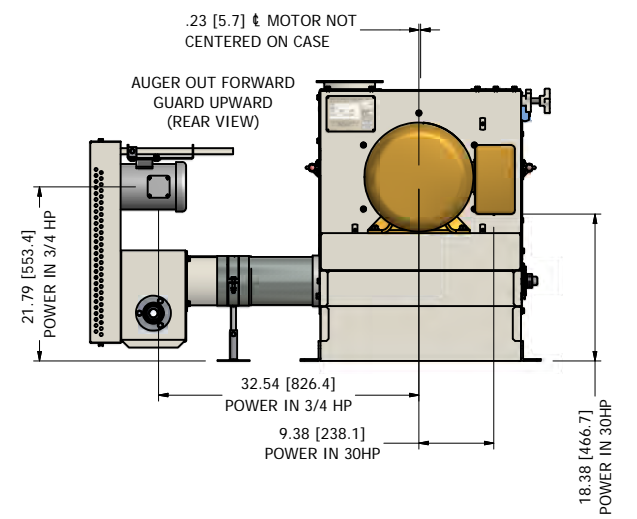
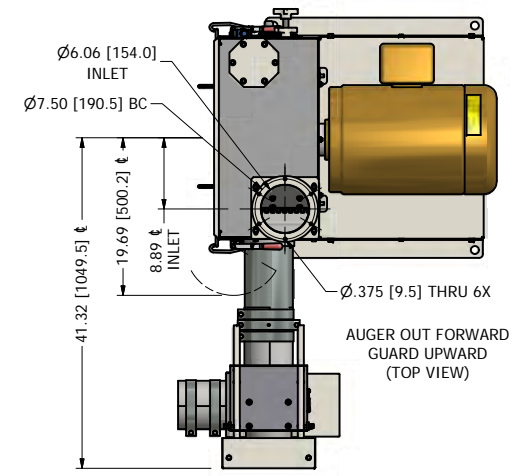
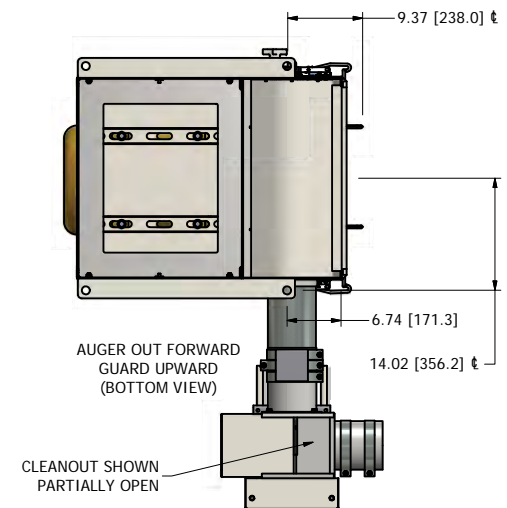
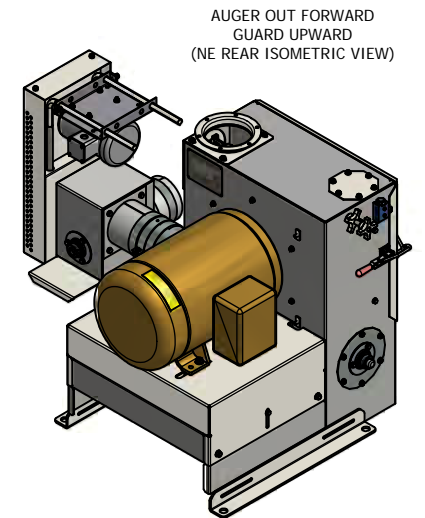
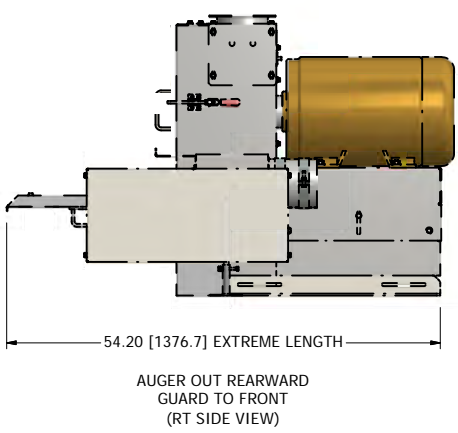
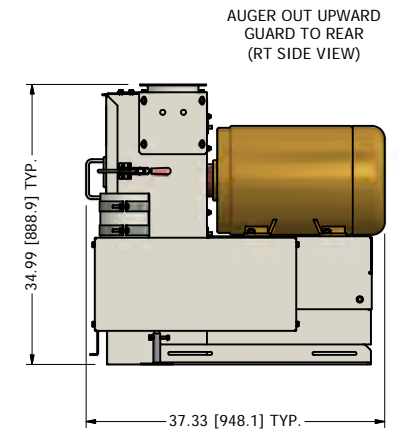
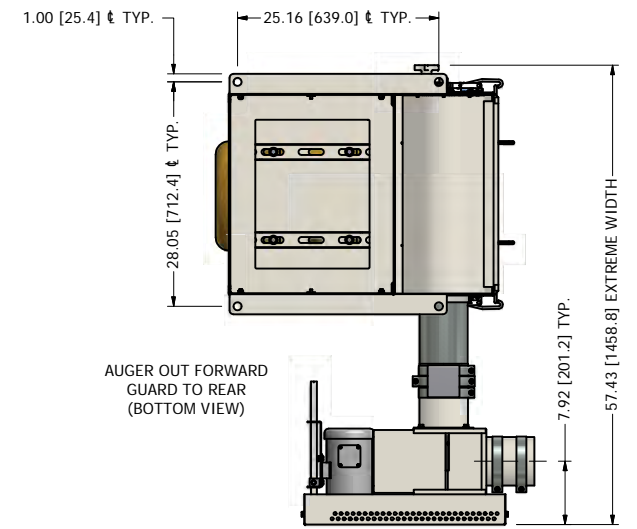
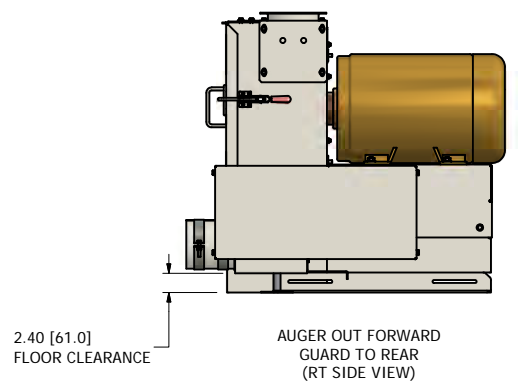
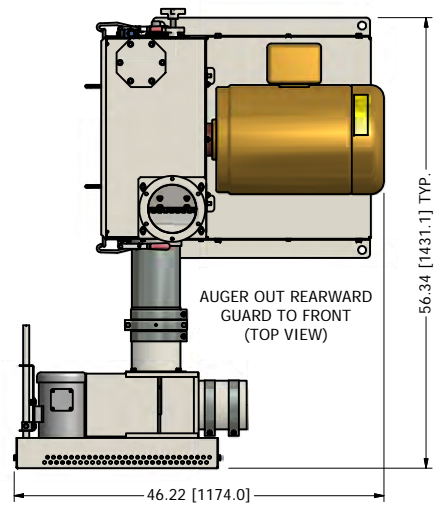

- NOTES:
- DO NOT SCALE FROM DRAWING.
 - ALT DIMENSIONS [X.X] IN MILLIMETERS.
 - RECOMMENDED MAINTENANCE CLEARANCE: FRONT: 36.00 [914.4], SIDE & REAR: 24.00 [609.6].
 - WEIGHT AS SHOWN WITH 30 HP DRIVE MOTOR: 657 LBS [298 KG].

This drawing is the property of the A.T. Ferrell Company, Inc and must be returned immediately upon request. No part of this drawing may be reproduced, stored in a retrieval system or transmitted in any form or by any means, without prior written consent of the A.T. Ferrell Company, Inc.	CAD NO MANUAL CHANGES TOLERANCES EXCEPT AS NOTED	 FEED PROCESSING SYSTEMS		DIVISION OF A. T. FERRELL COMPANY BLUFFTON, INDIANA - USA	
	DECIMAL: XXX ± .005 XX ± .030	FINISH: SCALE: 1:12	DRAWN BY: jmosse	APPROVED BY: DMJ	
	FRACTIONAL: ± 1/32	DATE: 7/12/2012	SIZE: D	PART NUMBER: 92007110-1	SHEET: 2 of 2
	ANGULAR: ± 1/2°				

REV	ECN	REVISION HISTORY	DATE	APPROVED
A	120054	DESCRIPTION RELEASE	7/16/2012	jmosse

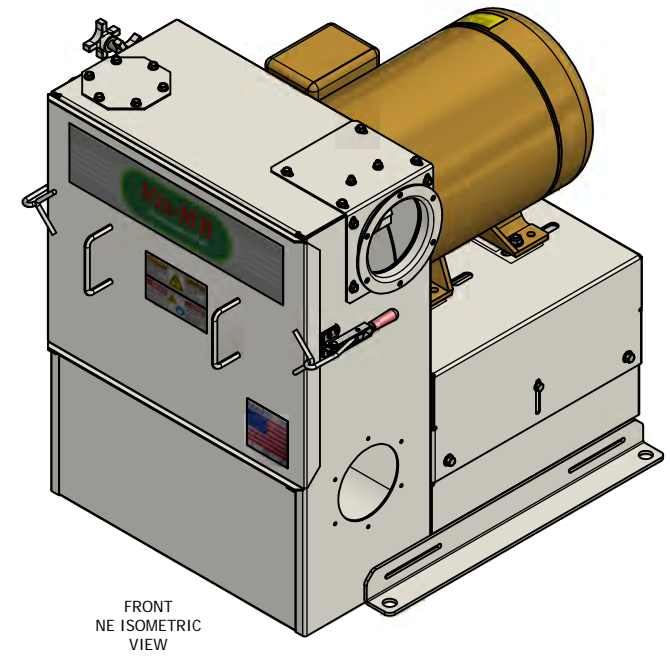
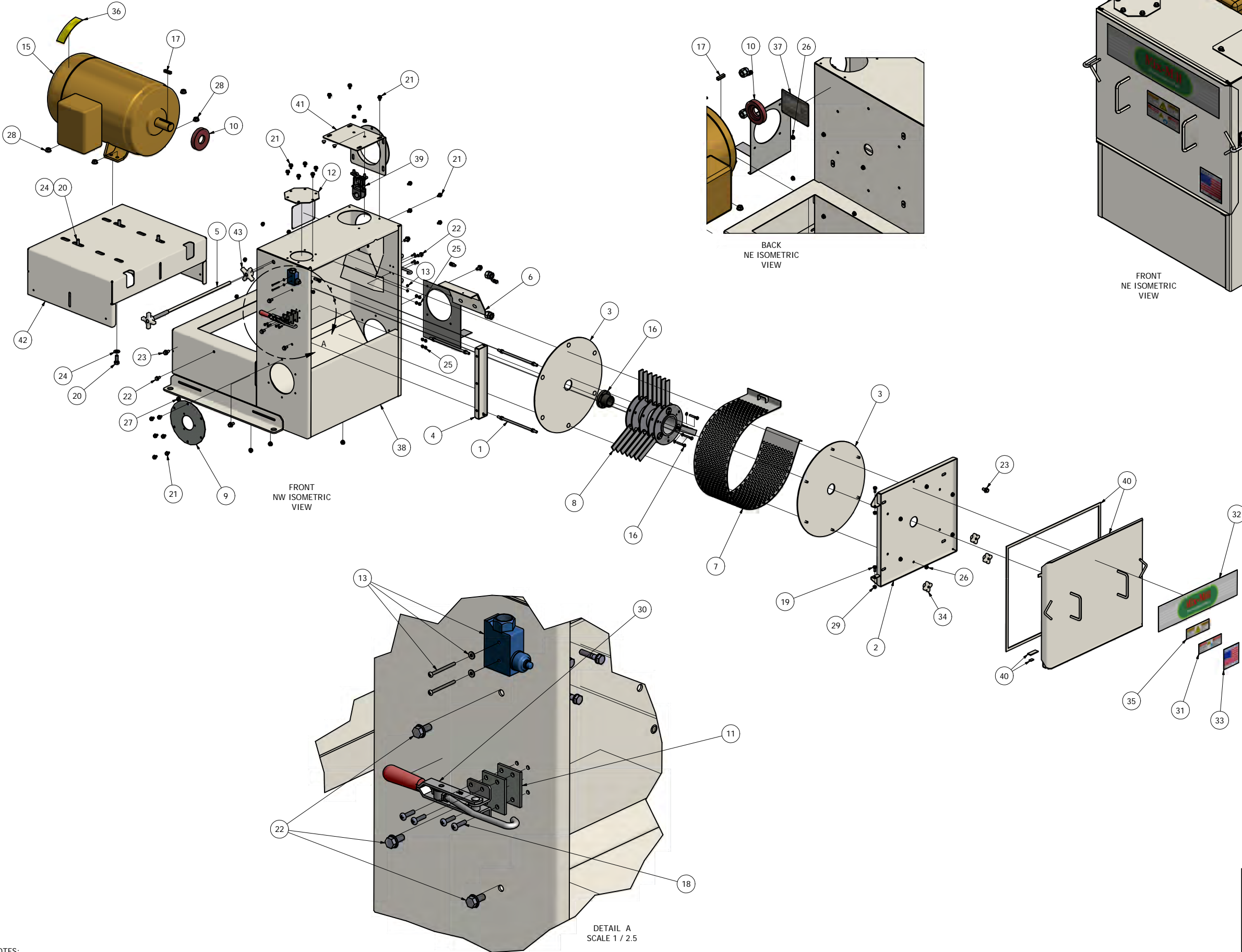

ITEM	PART NUMBER	QTY	DESCRIPTION
43	K910-01271	1	KNOB, NORTHWESTERN HK-5T 17510
42	90007190	1	BASE WLDMT, MOTOR, SENTRY 130
41	90007170	1	INLET WLDMT, 6" REVERSIBLE, SENTRY 130
40	90007150	1	DOOR WLDMT, OUTER, SENTRY 130
39	90007120	1	BRACKET ASSY, HANGER BEARING, 6" AUGER
38	90007110	1	MILL HOUSING, SIDE DISCHARGE WLDMT
37	80020017	1	PLATE, BUILD: CLIPPER, FERRELL-ROSS
36	80006517	1	DECAL, MOTOR WARRANTY SERVICE
35	80006506	1	DECAL, WARNING OPEN SWITCH
34	80006009	3	KNOB, 4-LOBE, 3/8-16 THRU
33	80003697	1	DECAL, MADE IN THE USA
32	80003662	1	DECAL, MIX-MILL 5 x 21
31	80003642	1	DECAL, WARNING, FAN BLADE
30	70004510	2	LATCH, MILL DOOR CL-250-PA
29	67003800	2	NUT, HEX NYLOCK 5/16-18
28	66785200	4	NUT, 1/2-13 HEX SERRATED
27	66784400	4	NUT, HEX SERR LOCK 3/8-16
26	66783800	20	NUT, HEX SERR LOCK 5/16-18
25	66782600	8	NUT, HEX SERR LOCK 10-24
24	66405200	4	WASHER, FLAT 1/2" TYPE A
23	65684417	5	HHCS, SERRATED WASHER HEAD, 3/8-16 X .75"
22	65683817	5	HHCS, SERR WASHER HEAD, 5/16-18 X 3/4"
21	65683812	16	SCW, MACH HX WSH HD T/C 5/16-18 X 1/2"
20	62585226	4	HHCS, 1/2-13 X 1.25"
19	62583817	2	HHCS, 5/16-18 X .75"
18	62342617	8	SCW, MACH, PAN HD, 10-24 X 3/4"
17	49000824	1	KEY, SQUARE .375 X 1.50"
16	44010720	1	BUSHING, QD SD 1.625"
15	33000715	1	MTR, 30HP 3536 0/6 230/460V TEFC 286TS
14	33000506	1	MTR 3/4HP 3D18 0/6 TEFC FT
13	31008025	1	SWITCH, MICRO, DOOR
12	11227150	1	COVER, 4" HOLE, 6 BOLT, SENTRY 130
11	11223070	4	MNT PLT, LATCH, D MILL
10	11221511	1	SEAL, FELT WASHER 1.63 ID X 4.00" OD, CUPPED
9	11194881	1	PLATE, IDLER BEARING BASE, 8.25"
8	10A383	1	BEATER HUB ASSY, 18" MILL
7	2A1467-K	1	SCREEN WLDMT, 8 X 18" SPLIT, 1/2", 188
6	2A1461	1	WEAR PLATE WLDMT, 6" AUGER BAFFLE, 188
5	2A1261	1	SCREEN TIGHTENER, WLDMT
4	2A1252	1	SUPPORT, INNER DOOR, 188
3	2A1251	2	WEAR PLATE WLDMT, SCREEN, 188
2	2A1250	1	DOOR WLDMT, INNER, 188
1	1A1814	3	SPACER WLDMT, INNER DOOR, 188

NOTES:
 1. DO NOT SCALE FROM DRAWING.
 2. * NOT INCLUDED IN BOM. SALES ORDER LINE ITEM.

This drawing is the property of the A.T. Ferrell Company, Inc and must be returned immediately upon request. No part of this drawing may be reproduced, stored in a retrieval system or transmitted in any form or by any means, without prior written consent of the A.T. Ferrell Company, Inc	CAD NO MANUAL CHANGES TOLERANCES EXCEPT AS NOTED	 DIVISION OF A. T. FERRELL COMPANY BLUFFTON, INDIANA - USA	FINISH: SCALE: 1:9 DRAWN BY: jmosse APPROVED BY: DMJ
	DECIMAL: .005 .01 .030 FRACTIONAL: 1/32 ANGULAR: 1/2		TITLE: MILL ASSY, SIDE DISCHARGE, SENTRY 1030 DATE: 7/12/2012 SIZE: D PART NUMBER: 92007110 SHEET: 1 of 1