

REV	ECN	DESCRIPTION	DATE	APPROVED
A	100019	RELEASED	2/24/2010	PG

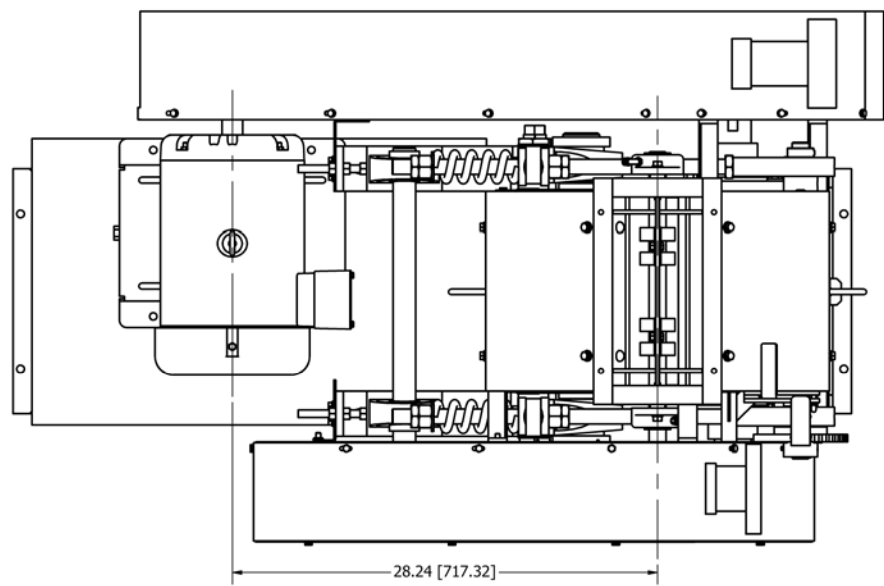

TOP VIEW

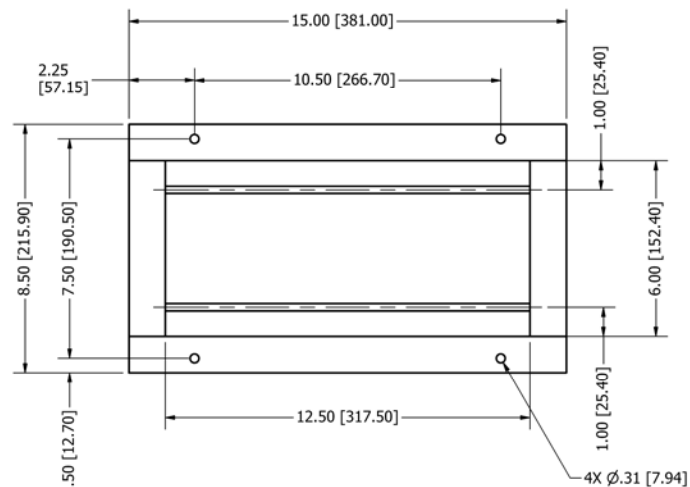

TOP VIEW
INLET FLANGE

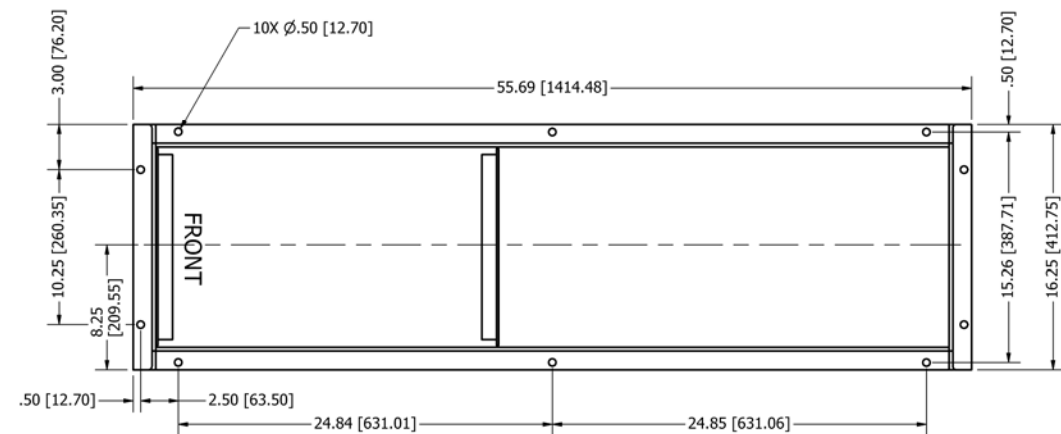

TOP VIEW
MOTOR STAND MOUNTING DETAIL

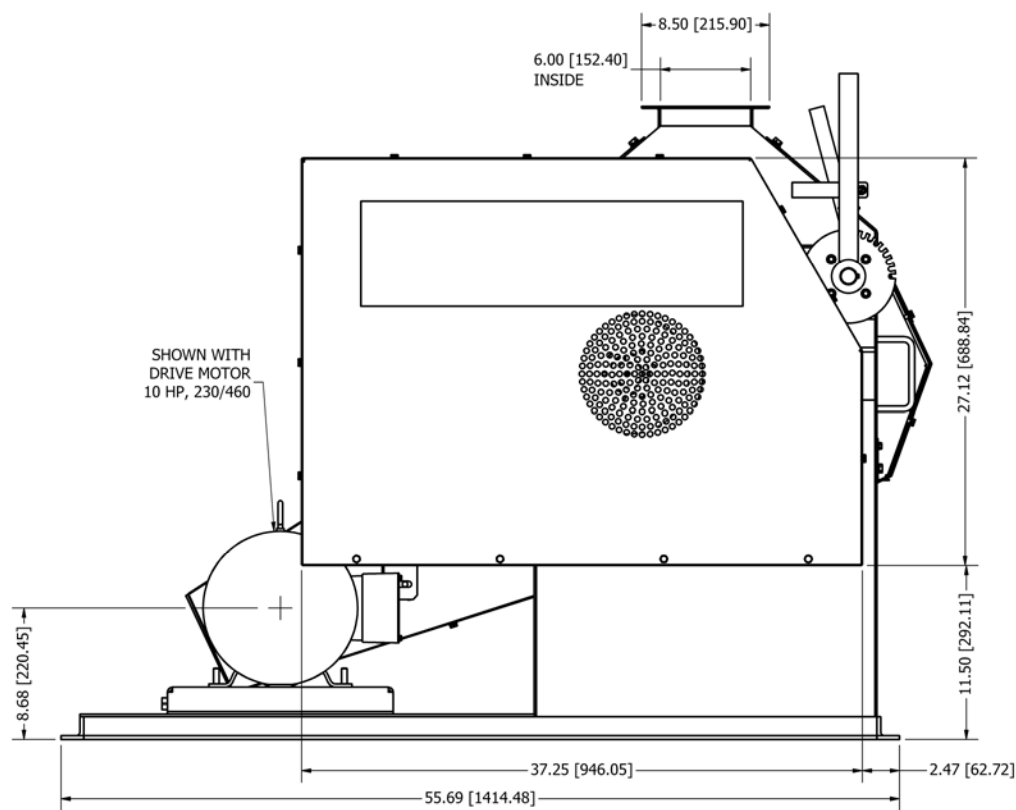

LEFT SIDE VIEW

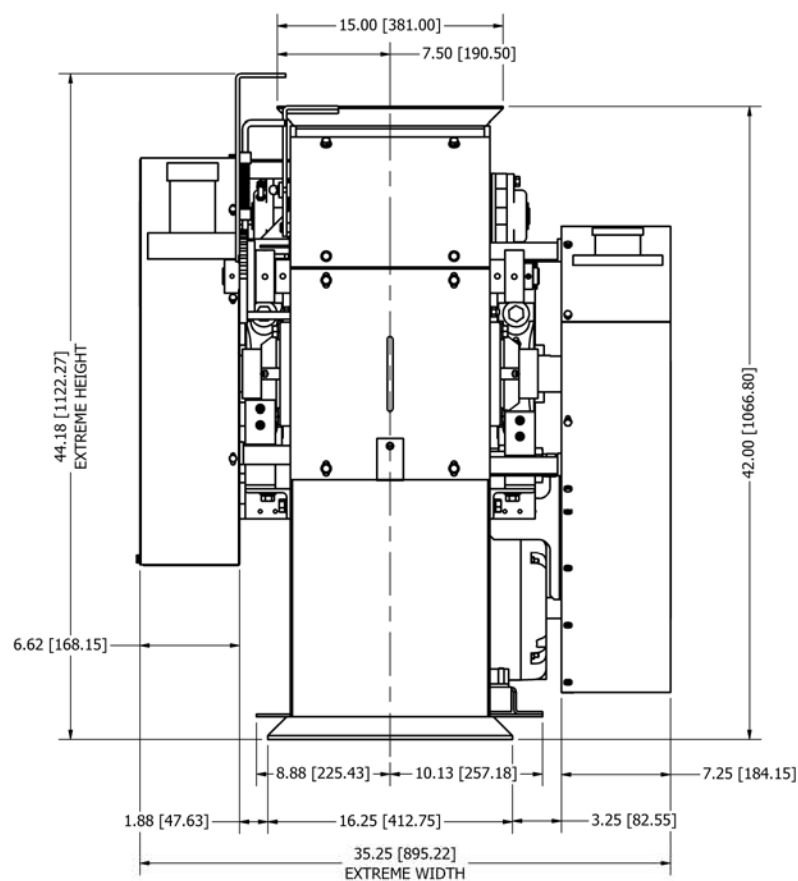

FRONT VIEW

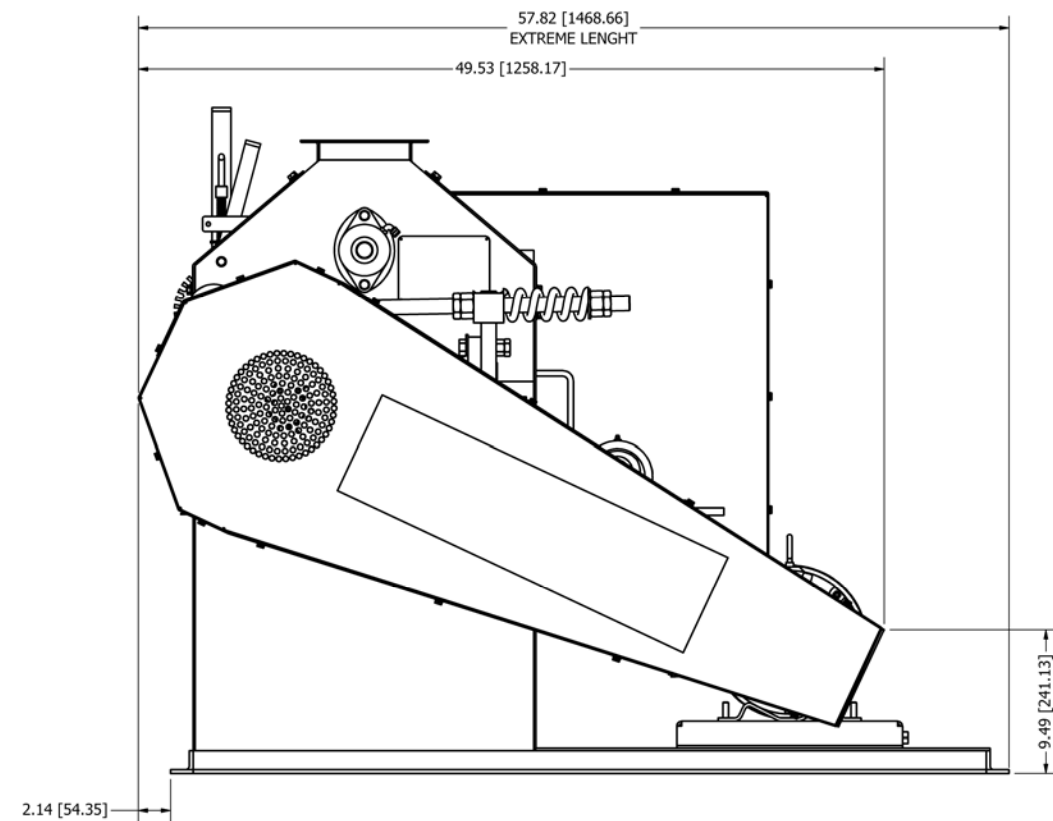

RIGHT SIDE VIEW

- NOTES:
- DO NOT SCALE FROM DRAWING.
 - ALTERNATIVE UNITS (XX.XX) IN MILLIMETERS.
 - SHIPPING WEIGHT (COMPLETE WITH MOTOR) 1,500 LBS [681.82 KG].
 - RECOMMENDED MAINTENANCE CLEARANCE FOR MILL 48.00 (1219) AT FRONT & SIDES 12.00" (305) AT REAR.
 - PIVOT ROLLS MUST BE REMOVED FROM FRONT OF HOUSING, FIXED ROLLS MUST BE REMOVED FROM THE REAR.
 - MILL HOUSING HR LOW CARBON STEEL PAINTED FINISH, OTHER GRADES OF CARBON STEEL, STAINLESS STEEL, EPOXY & FOOD GRADE FINISH AVAILABLE UPON REQUEST.

This drawing is the property of the A.T. Ferrell Company, Inc and must be returned immediately upon request. No part of this drawing may be reproduced, stored in a retrieval system or transmitted in any form or by any means, without prior written consent of the A.T. Ferrell Company, Inc.	CAD NO MANUAL CHANGES		DIVISION OF A. T. FERRELL COMPANY BLUFFTON, INDIANA - USA				
	TOLERANCES EXCEPT AS NOTED		FINISH: TOUCH-UP PAINT	SCALE: 0.16:1	DRAWN BY: pggalea	APPROVED BY:	
	DECIMAL: .005 XX .030		TITLE: MILL, M10 X 12" SGL BASE ASSY	DATE: 2/1/2010	SIZE: D	PART NUMBER: 92000841-1	SHEET: 1 of 1
	FRACTIONAL: 1/32 ANGULAR: 1/2						