

Clipper 768 Precision Cleaner



Technical Specifications

- Extreme Height 138"/ 351 cm
- Height with Bottom Fan 155"/394 cm
- Extreme Width 89"/ 226 cm
- Extreme Length 189"/ 480 cm
- Width on floor 72"/ 183 cm
- Length on floor 189"/ 480 cm

Electrical Requirements

- Main Fan Motor 15 HP, 3 Phase, AC
- Vibratory Feeder ½ HP, AC or DC
- Eccentric Motor 5 HP, 3 Phase, AC

Air Output

- Integral Centrifugal Fan delivering up to 8,400 CFM @ 8" S.P

Features

- Heavy Duty Construction-Built to last
- Electronic Vibratory Feed Hopper
- Screen Pitch: Top Shoe 8°
Bottom Shoe 9°
- Uses Standard Size Clipper Screens:
25 Screen Sections of 54" x 26"
- Feed Hopper & Aspiration Column
Engineered for High Capacity

Capacity

- Large Seed/Wheat 1000-1500 Bu./Hr.
(27-40.5 MT/H)
- Market Cleaning 2000-2500 Bu./Hr.
(54-67.5 MT/H)

Options

- Bottom Blast Fan
- Grease Package

Note: Capacities may vary depending on seed condition, moisture content, seed varieties, types and volumes of contaminants to be separated and the percentage of foreign material acceptable in the final product.



1440 SOUTH ADAMS STREET, BLUFFTON IN 46714 (260) 824-3400, (800) 248-8318, FAX (260)-824-5463
info@atferrell.com www.clipperseparation.com

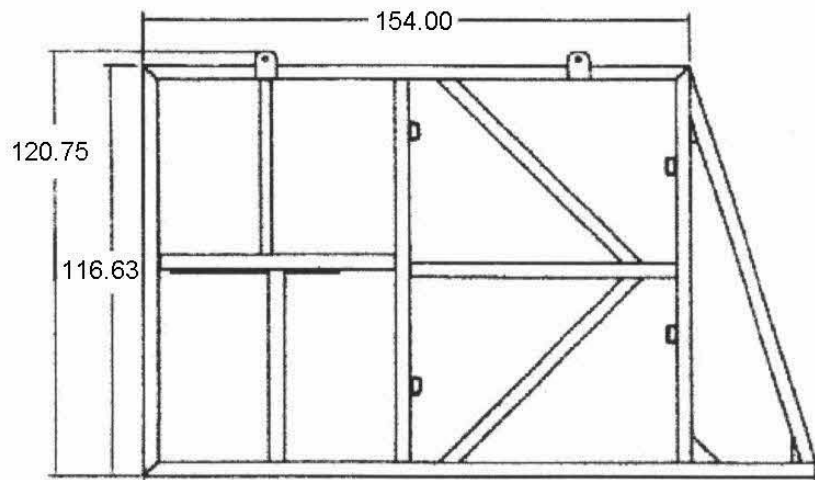

SIDE VIEW

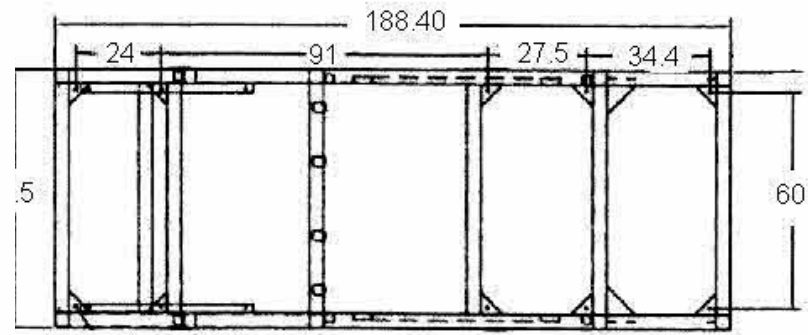

BOTTOM VIEW

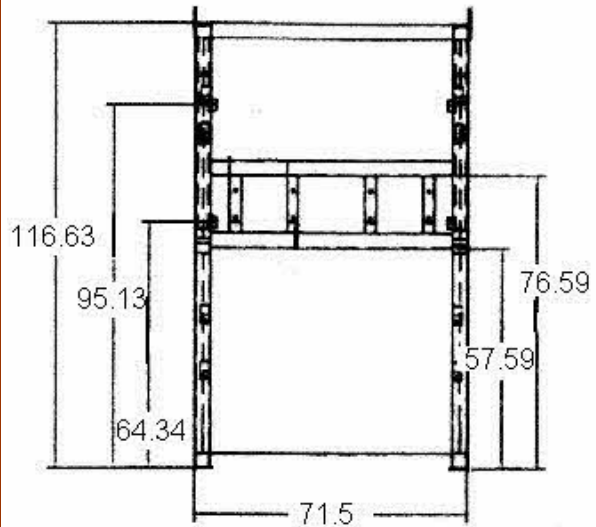

FRONT VIEW

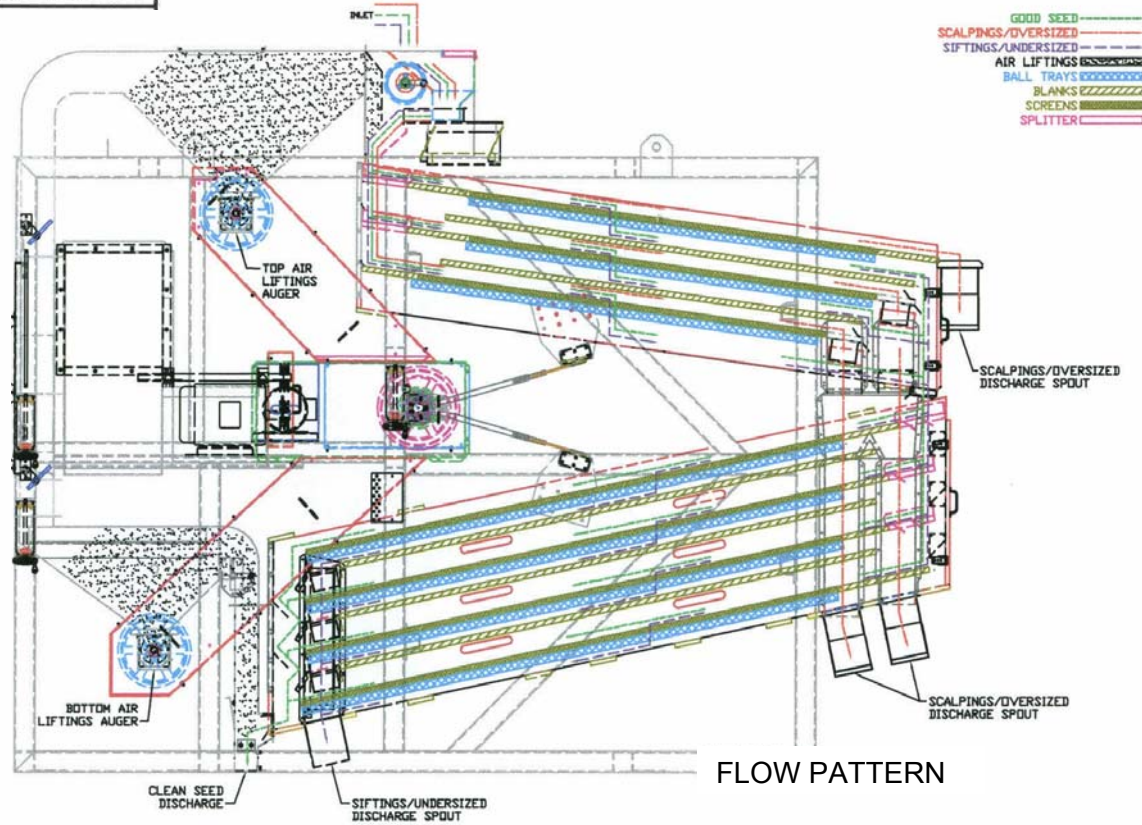

FLOW PATTERN